



# LBC 3700/00 Horn Loudspeaker



- ▶ High quality music horn for excellent speech and music reproduction
- ▶ Two-way system
- ▶ High sensitivity
- ▶ Wide opening angle
- ▶ Simple power setting
- ▶ Water and dust protected to IP 65
- ▶ Attractive ABS housing
- ▶ Complies with international installation and safety regulations

The Bosch LBC 3700/00 Horn Loudspeaker features an extended frequency range and high sensitivity which makes it ideal for high quality speech and music reproduction. The wide opening angle ensures even sound distribution, so fewer horns are needed to cover a given area.

## Functions

The rectangular horn features a unique combination of a re-entrant horn with two transducers, one for low- and the other for high frequencies, resulting in breathtaking sound clarity.

The horn is weather protected and can be used in areas with high humidity. It is therefore suitable for outdoor applications such as swimming pools, sports stadiums, leisure parks, cruise ships, schools and train stations, as well as for indoor public address. Finished in light grey RAL 7035 color, the ABS horn is both stylish and lightweight.

## Certifications and Approvals

All Bosch loudspeakers are designed to withstand operating at their rated power for 100 hours in accordance with IEC 268-5 Power Handling Capacity (PHC) standards. Bosch has also developed the Simulated Acoustical Feedback Exposure (SAFE) test to demonstrate that they can

withstand two times their rated power for short durations. This ensures extra reliability under extreme conditions, leading to higher customer satisfaction, longer operating life, and much less chance of failure or performance deterioration.

Safety	acc. to EN 60065
Water and dust protected	acc. to IEC 60529, IP 65
Self-extinguishing ABS	acc. to UL 94 V0

## Installation/Configuration Notes

The 100 V horn loudspeaker includes a transformer with taps on the primary winding for different power settings. Nominal full-power, half-power, quarter-power or eight-power radiation (i.e. in 3 dB steps) can easily be selected by connected the 100 V line to the appropriate tap. The horn loudspeaker is supplied with a sturdy aluminum (corrosion resistant) mounting bracket allowing the sound beam to be accurately directed.

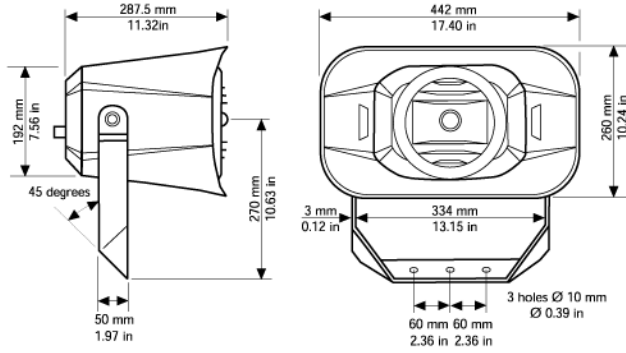

Dimensions in mm (in)

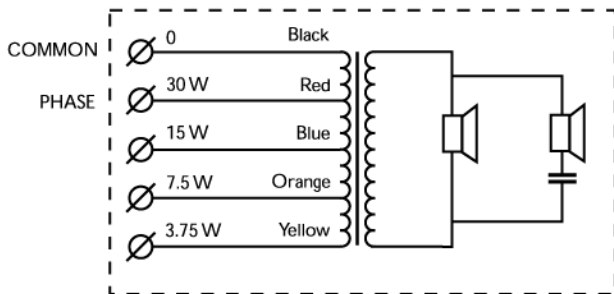

Circuit diagram

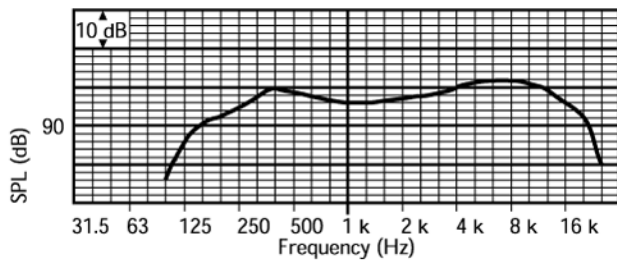

Frequency response

	125 Hz	250 Hz	500 Hz	1 kHz	2 kHz	4 kHz	8 kHz
SPL 1.1	88	97	97	97	98	100	102
SPL max.	103	112	112	112	113	115	117
Q-factor	1.4	2.2	3.7	7.1	8.5	7.4	16.2
Efficiency	0.6	2.8	1.7	0.9	0.9	1.7	1.2
H. angle	360	360	120	105	85	90	65
V. angle	360	360	200	110	100	125	55

Acoustical performance specified per octave

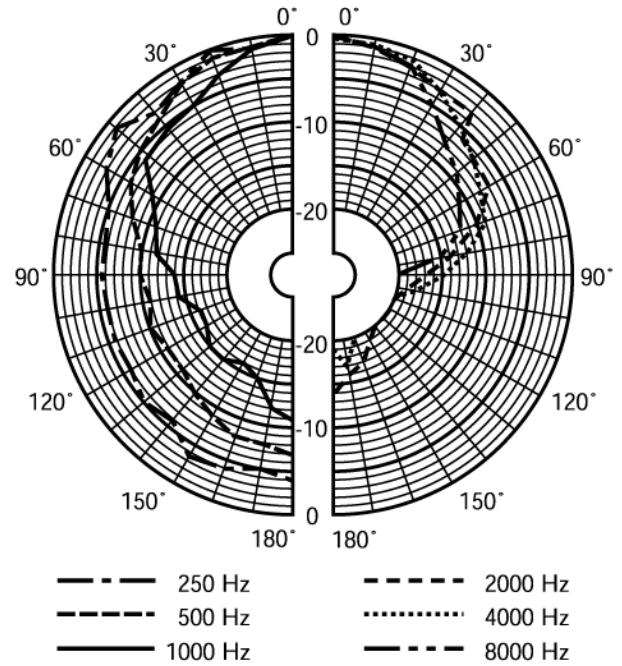

Polar diagram horizontal (measured with pink noise)

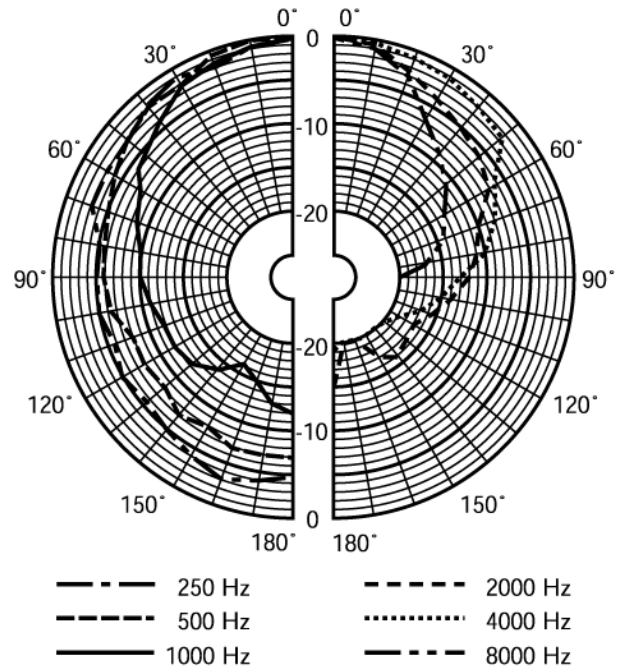

Polar diagram vertical (measured with pink noise)

## Technical Specifications

### Electrical\*

Maximum power	45 W
Rated power	30 / 15 / 7.5 / 3.75 W
Sound pressure level at 30 W / 1 W (1 kHz, 1 m)	112 dB / 97 dB (SPL)
Effective frequency range (-10 dB)	125 Hz to 20 kHz
Opening angle horizontal	1 kHz / 4 kHz (-6 dB) 105° / 90°
vertical	110° / 125°
Rated voltage	100 V
Rated impedance	333 ohm
Connector	Screw terminal block

\* Technical performance data acc. to IEC 60268-5

### Mechanical

Dimensions (H x W x D)	260 x 442 x 287.5 mm (10.2 x 17.4 x 11.3 in)
Weight	5 kg (11 lb)
Color	Light grey (RAL 7035)
Cable diameter	6 mm to 8 mm (0.24 in to 0.31 in)

### Environmental

Operating temperature	-25 °C to +55 °C (-13 °F to +131 °F)
Storage temperature	-40 °C to +70 °C (-40 °F to +158 °F)
Relative humidity	<95%

## Ordering Information

LBC 3700/00 Horn Loudspeaker	LBC 3700/00
<b>Accessories</b>	
LBC 1256/00 EVAC Connection Adapter 3-pole screw connector, 100 pieces	LBC 1256/00

**Europe, Middle East, Africa:**  
Bosch Security Systems B.V.  
P.O. Box 80002  
5600 JB Eindhoven, The Netherlands  
Phone: + 31 40 2577 284  
Fax: +31 40 2577 330  
emea.securitysystems@bosch.com  
www.boschsecurity.com

**Americas:**  
Bosch Security Systems, Inc.  
130 Perinton Parkway  
Fairport, New York, 14450, USA  
Phone: +1 800 289 0096  
Fax: +1 585 223 9180  
security.sales@us.bosch.com  
www.boschsecurity.us

**Asia-Pacific:**  
Bosch Security Systems Pte Ltd  
38C Jalan Pemimpin  
Singapore 577180  
Phone: +65 6319 3450  
Fax: +65 6319 3499  
apr.securitysystems@bosch.com  
www.boschsecurity.com

**Represented by**