



*User's Manual*

# *convert 15A series*



Antes de utilizar el equipo, lea la sección "Precauciones de seguridad" de este manual. Conserve este manual para futuras consultas.

Before operating the device, please read the "Safety precautions" section of this manual. Retain this manual for future reference.

## CONTENTS

<b>SAFETY PRECAUTIONS</b> .....	<b>3</b>
<b>WARRANTY</b> .....	<b>4</b>
<b>DECLARATION OF CONFORMITY</b> .....	<b>5</b>
<b>INTRODUCTION</b> .....	<b>6 a 7</b>
<b>CONFIGURATIONS</b> .....	<b>8 a 9</b>
Without <i>DASnet™</i>	
With <i>DASnet™</i>	
<b>LINE DRAWINGS</b> .....	<b>10</b>
<b>AMPLIFIER</b> .....	<b>11 a 13</b>
Description	
ON / OFF	
Overload indicator	
Equalization	
Overheating	
Low mains voltage	
Current consumption	
Troubleshooting	
<b>CHANGE OF CONFIGURATION</b> .....	<b>14 a 17</b>
<b>SPECIFICATIONS</b> .....	<b>18</b>
<b>RIGGING SYSTEM</b> .....	<b>19 a 20</b>
<b>APPENDIX</b> .....	<b>21</b>
<u>Line connections: unbalanced and balanced</u>	



El signo de exclamación dentro de un triángulo indica la existencia de importantes instrucciones de operación y mantenimiento en la documentación que acompaña al producto. Conserve y lea todas estas advertencias. **ATENCIÓN:** Es un producto clase A, por lo que en entornos domésticos puede causar radio-interferencias, en cuyo caso el usuario tendrá que tomar las medidas oportunas. De acuerdo con EN55103-2, usar el equipo sólo en entornos E1, E2, E3 ó E4.



No desconecte la tierra en el conector de alimentación pues es peligroso e ilegal. Equipo de Clase I.

El signo del rayo con la punta de flecha, alerta contra la presencia de voltajes peligrosos no aislados. Para reducir el riesgo de choque eléctrico, no retire la cubierta.



Sólo use este equipo con el cable de red de alimentación adecuado para su país.

No instale el aparato cerca de ninguna fuente de calor como radiadores, estufas u otros aparatos que produzcan calor. Debe instalarse siempre sin bloquear la libre circulación de aire por las aletas del radiador.

No exponga este equipo a la lluvia o humedad. No use este aparato cerca del agua (piscinas y fuentes, por ejemplo). No exponga el equipo a salpicaduras ni coloque sobre él objetos que contengan líquidos, tales como vasos y botellas. Equipo IP-20.

Este símbolo indica que el presente producto no puede ser tratado como residuo doméstico normal, sino que debe entregarse en el correspondiente punto de recogida de equipos eléctricos y electrónicos.



Equipo diseñado para funcionar entre 15°C y 42°C con una humedad relativa máxima del 95%, con un rango de  $\pm 10\%$  de la tensión nominal de alimentación indicada en la etiqueta trasera (según IEC 60065:2001). Si se debe sustituir el fusible interior preste atención al tipo y rango.

El cableado exterior conectado al equipo requiere de su instalación por una persona instruida o el uso de cables flexibles ya preparados.

Si el aparato es conectado permanentemente, la instalación eléctrica del edificio debe incorporar un interruptor multipolar con separación de contacto de al menos 3mm en cada polo.

Desconecte este aparato durante tormentas eléctricas, terremotos o cuando no se vaya a emplear durante largos periodos.

No emplace altavoces en proximidad a equipos sensibles a campos magnéticos, tales como monitores de televisión o material magnético de almacenamiento de datos.



El colgado del equipo sólo debe realizarse utilizando los herrajes de colgado recomendados y por personal cualificado. No cuelgue la caja de las asas.

No existen partes ajustables por el usuario en el interior de este equipo. Cualquier operación de mantenimiento o reparación debe ser realizada por personal cualificado. Es necesario el servicio técnico cuando el equipo se haya dañado de alguna forma, como que haya caído líquido o algún objeto en el interior del aparato, haya sido expuesto a lluvia o humedad, no funcione correctamente, haya recibido un golpe o su cable de red esté dañado.

Limpie con un paño seco. No use limpiadores con disolventes.

The exclamation point inside an equilateral triangle is intend to alert the users to the presence of important operating and maintenance (servicing) instructions in the literature accompanying the product. Heed all warnings. Follow all instructions. Keep these instructions.

**WARNING:** This is a class A product. In a domestic environment this product may cause radio interferences in which case the user may be required to take adequate measures.

Use this product only in E1, E2, E3 or E4 environments according to EN55103-2.

Do not remove mains connector ground, it is dangereous and illegal. Class I device.

The lightning and arrowhead symbol warns about the presence of uninsulated dangerous voltage. To reduce the risk of electric shock, do not remove the cover.

Only use this equipment with an appropriate mains cord for your country.

Do not install near any heat sources such as radiators, heat registers, stoves or other apparatus that produce heat.

The circulation of air through the heatsink must not be blocked.

Do not expose this device to rain or moisture. Do not use this apparatus near water (for example, swimming pools and fountains). Do not place any objects containing liquids, such as bottles or glasses, on the top of the unit. Do not splash liquids on the unit. IP-20 equipment.

This symbol on the product indicates that this product should not be treated as household waste. Instead it shall be handed over to the applicable collection point for the recycling of electrical and electronic equipment.

Working temperature ranges from 15°C to 42°C with a relative humidity of 95%, with  $\pm 10\%$  of the rated main voltage value indicated on the rear label (according to IEC 60065:2001). If the internal fuse needs to be replaced, please pay attention to correct type and ratings.

The outer wiring connected to the device requires installation by an instructed person or the use of a flexible cable already prepared.

If the apparatus is connected permanently, the electrical system of the building must incorporate a multipolar switch with a separation of contact of at least 3mm in each pole.

Unplug this apparatus during lightning storms, earthquakes or when unused for long periods of time.

Do not place loudspeakers in proximity to devices sensitive to magnetic fields such as television monitors or data storage magnetic material.

The appliance should be flown only from the rigging points and by qualified personnel. Do not suspend the box from the handles.

No user serviceable parts inside. Refer all servicing to qualified service personnel. Servicing is required when the apparatus has been damaged in any way, such as power-supply cord or plug is damaged, liquid has been spilled or objects have fallen into the apparatus, the apparatus has been exposed to rain or moisture, does not operate normally or has been dropped.

Clean only with a dry cloth. Do not use any solvent based cleaners.

## **GARANTÍA**

Todos nuestros productos están garantizados por un periodo de 24 meses desde la fecha de compra.

Las garantías sólo serán válidas si son por un defecto de fabricación y en ningún caso por un uso incorrecto del producto.

Las reparaciones en garantía pueden ser realizadas, exclusivamente, por el fabricante o el servicio de asistencia técnica autorizado.

Otros cargos como portes y seguros, son a cargo del comprador en todos los casos.

Para solicitar reparación en garantía es imprescindible que el producto no haya sido previamente manipulado e incluir una fotocopia de la factura de compra.

## **WARRANTY**

All D.A.S. products are warrantied against any manufacturing defect for a period of 2 years from date of purchase.

The warranty excludes damage from incorrect use of the product.

All warranty repairs must be exclusively undertaken by the factory or any of its authorised service centers.

To claim a warranty repair, do not open or intend to repair the product.

Return the damaged unit, at shippers risk and freight prepaid, to the nearest service center with a copy of the purchase invoice.





## DECLARACIÓN DE CONFORMIDAD DECLARATION OF CONFORMITY

### **D.A.S. Audio, S.A.**

C/ Islas Baleares, 24 - 46988 - Pol. Fuente del Jarro - Valencia. España (Spain).

Declara que la *serie convert 15A*:

Declares that *convert 15A series*:

Cumple con los objetivos esenciales de las Directivas:

Abide by essential objectives relating Directives:

- Directiva de Baja Tensión (Low Voltage Directive) 2006/95/CE
- Directiva de Compatibilidad Electromagnética (EMC) 2004/108/CE
- Directiva RoHS 2002/95/CE
- Directiva RAEE (WEEE) 2002/96/CE

Y es conforme a las siguientes Normas Armonizadas Europeas:

In accordance with Harmonized European Norms:

- EN 60065:2002 Audio, video and similar electronic apparatus. Safety requirements.
- EN 55103-1:1996 Electromagnetic compatibility. Product family standard for audio, video, audio-visual and entertainment lighting control apparatus for professional use. Part 1:Emission.
- EN 55103-2:1996 Electromagnetic compatibility. Product family standard for audio, video, audio-visual and entertainment lighting control apparatus for professional use. Part 2:Immunity.

## INTRODUCTION

The new *convert 15A serie* arrayable loudspeaker is a powered, multi-purpose system incorporating a series of breakthrough features that offer an unmatched level of versatility and performance. As its name implies, the system's coverage capabilities can be easily "converted" to meet the specific requirements of almost any application. An innovative electronics and digital signal processing package combined with ground-breaking horn design offers "user-definable" optimization of the system's dispersion characteristics. This allows the *convert 15A* to be deployed in either horizontal or vertical curved source arrays, or used individually as a point source.

Add to these unique features, a powerful 2000 W, 3 channel, Class D amplifier, connectivity for system management and control, and optional rigging hardware for safe flying or ground-stacking, and you have a loudspeaker system engineered for exceptional flexibility and outstanding performance.

The new *convert 15A serie* is integrated for the models: *convert 1560A*, *convert 1590A*, *convert 1560RA* and *convert 1590RA*, these latter with Rigging System.

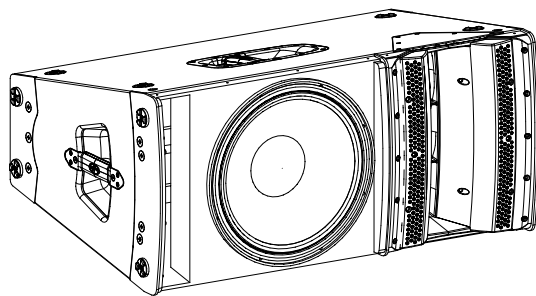

*convert 1560A*

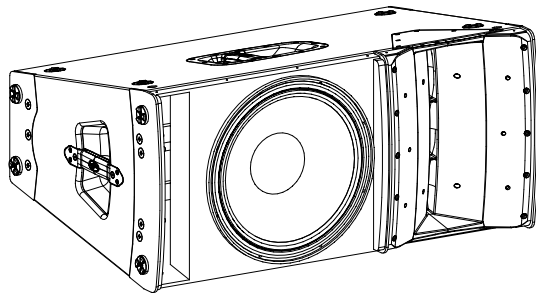

*convert 1590A*

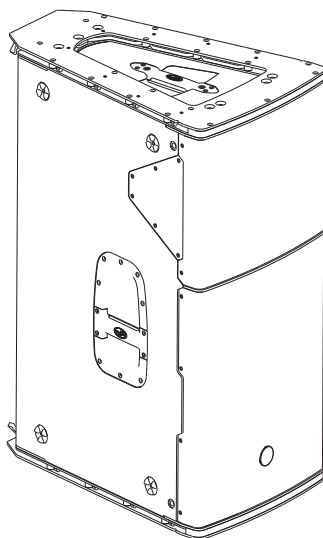

*convert 1560RA & convert 1590RA*

### Features

- Multifunction system with variable dispersion
- Three channel amplifier with:
  - 1000W LF + 500W HF<sub>1</sub> + 500W HF<sub>2</sub>
- 15 GNR bass loudspeaker
- Three M-60N Neodymium compression drivers
- Variable dispersion by way of DCD™ presets
- DASnet™ communications capable
- Captive rigging system (-RA version)

Line array units exhibit narrow dispersion on the coupling plane and wide coverage on the non-coupling plane. These coverage characteristics, needed to perform in multi-unit arrays, drastically reduce their ability to be used as individual units. In order to overcome this obstacle and convert the narrow coverage needed for an array, to the wider coverage needed to use the *convert 15A* as an individual unit, **D.A.S.** engineers developed the *Digitally Convertible Dispersion™ (DCD™)*, a proprietary signal management interface which employs complex signal processing via an advanced DSP. By means of the *DCD™*, the dispersion on the coupling plane of the *convert 15A* can be switched from 20° to 40°. Configuring the coverage characteristics of the *convert 15A* is surprisingly simple. Switching the dispersion from 20° to 40° is as easy as selecting one of the digital presets directly from the *DCD™* interface on the rear of the cabinet or remotely via *DASnet™*.

Powering the *convert 15A* is a package of integrated electronics that includes the *DCD™* interface, the digital signal processing engine and a new 2,000 W (4,000 Wpeak) amplifier. The three channel, high efficiency Class D design is equipped with a switch mode power supply (SMPS) and a comprehensive protection package for both the amplifier as well as the components. One channel powers the low frequency way, and the other two channels power the high frequency drivers.

The *DCD™* incorporates the latest in digital signal processors. Brickwall FIR filters have been used to provide perfect alignment between ways achieving exceptionally uniform coverage all the way down to the crossover point. The top-of-the-line AD/DA converters employed allow for significant improvements in dynamics, lower distortion and ultra-low noise levels.

### Horizontal dispersions according DCD™

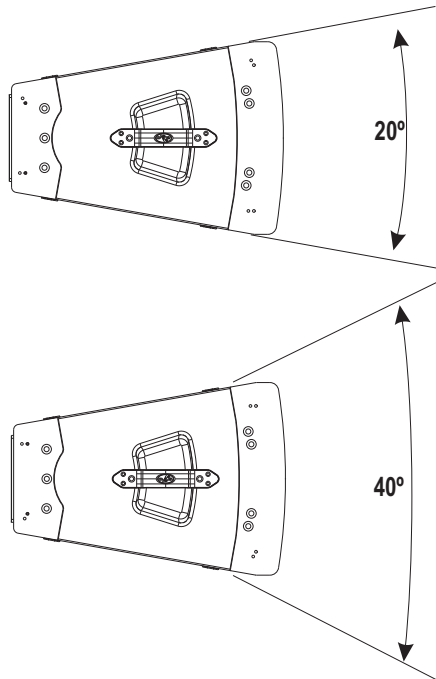

### Vertical dispersions according the model

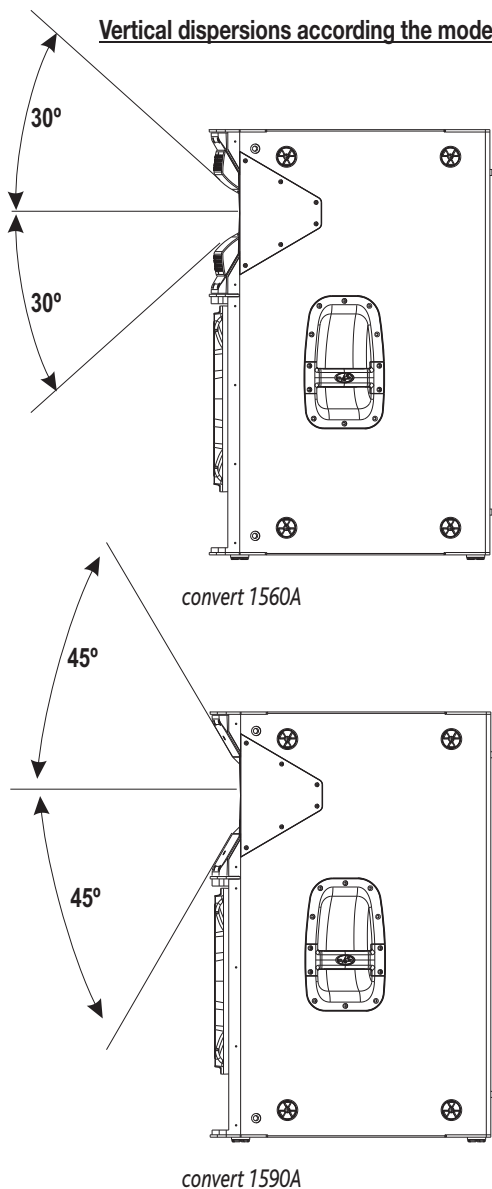

Remote monitoring is provided by way of the *DASnet™* monitoring system and software, an audio management application for **D.A.S.** powered cabinets and processors. The *DASnet™* software offers users instant and intuitive control over a range of parameters of a single cabinet or processor via USB, or a network of them via RS485.

The wide frequency range and impressive output of the *convert 15A* is possible thanks to the **D.A.S.** built transducer components. For the high impact, low frequency reproduction required in a system of this level, **D.A.S.** employs the *15GNR* loudspeaker, a 15" device incorporating a 102 mm (4") edge-wound voice coil and a light-weight neodymium magnet assembly

Three *M-60N* neodymium compression drivers are used to handle high frequency reproduction. The drivers employ a 44 mm (1.75") voice coil made using copper clad aluminum flat wire bonded to a urea polyamide diaphragm. This high performance thermoplastic, improves sensitivity and acoustic output as well as timbre. The M-60N units are attached to the new *BPS-320 dSerpis™* trifunctional waveguide.

The new generation of Serpis waveguide technology is exhibited in the extraordinary design of the *BPS-320 dSerpis™*. Producing a time-aligned, phase coherent 20° wave front, the *BPS-320 dSerpis™* maximizes the combined output of the three *M-60N* drivers. When used in tight-packed horizontal or vertical curved source arrays, the *BPS-320 dSerpis™* provides extremely tight pattern control with minimal interaction between horns.

As a point source, the drivers receive the *DCD™* processed signal widening the curvature of the wavefront to 40°. This permits the *convert 15A* to be used as a single cabinet or pairs of cabinets delivering the required coverage to a broader area.

The *convert 15A* enclosure is constructed using birch plywood and finished with the ISO-flex black paint providing excellent protection and durability. The 20° trapezoidal shape of the *convert 15A* enclosure allows for tightly packed arrays with minimal high frequency interaction. As an aid when stacking the enclosures in vertical arrays, rubber locators on the side panels match with fitting points on the surfaces of adjacent cabinets preventing slippage.

The optional *InterLox™* rigging system can be used to quickly and safely assemble tight-packed vertical or horizontal curved-source arrays. M-10 threaded rigging points are provided for use in permanent installation (for more information see **Rigging Manual**).

## CONFIGURATIONS

Below, two example configurations. In our website you can find more settings.

Example: Without *DASnet™*

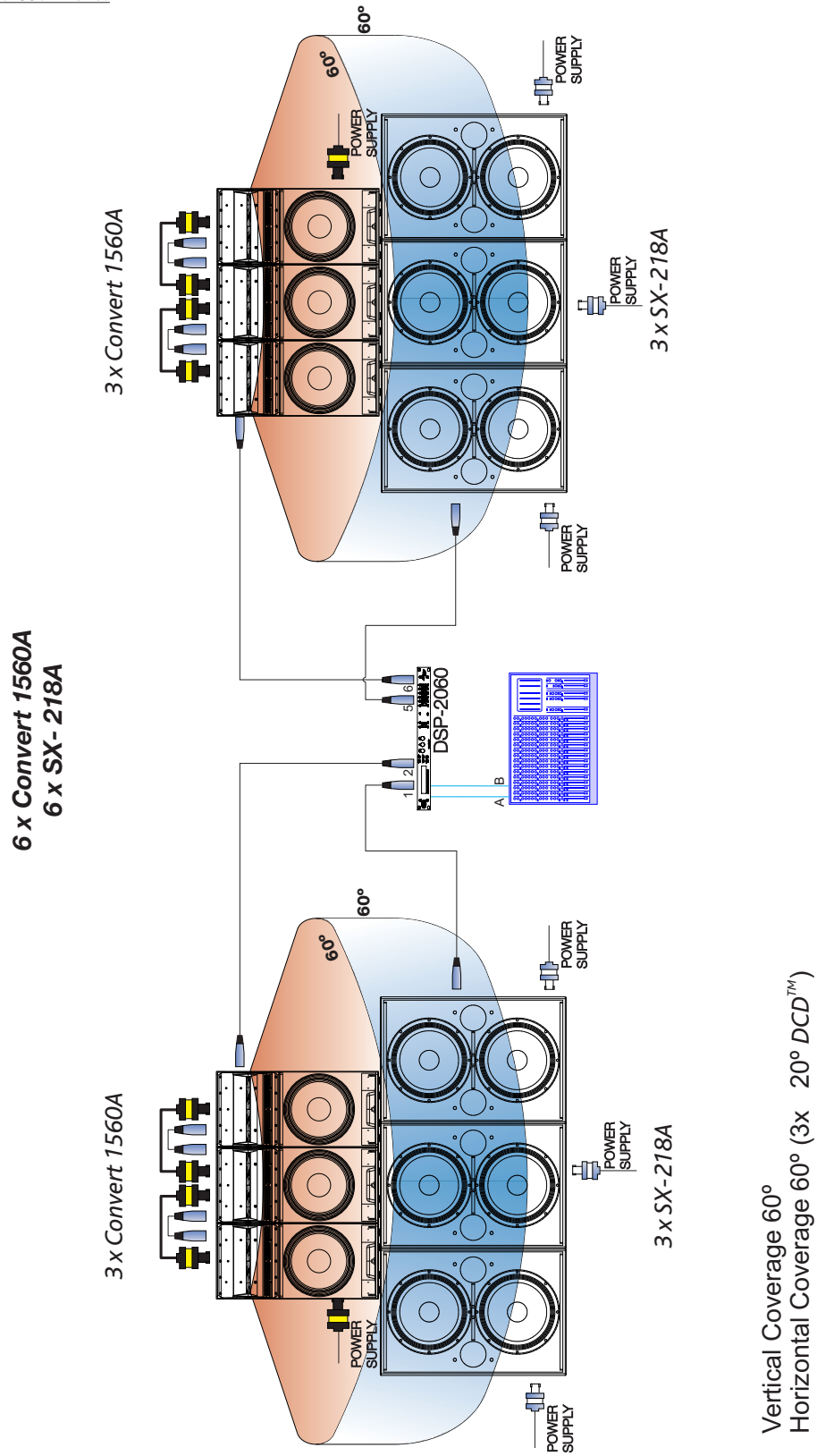

**CONFIGURATIONS (cont'd)**



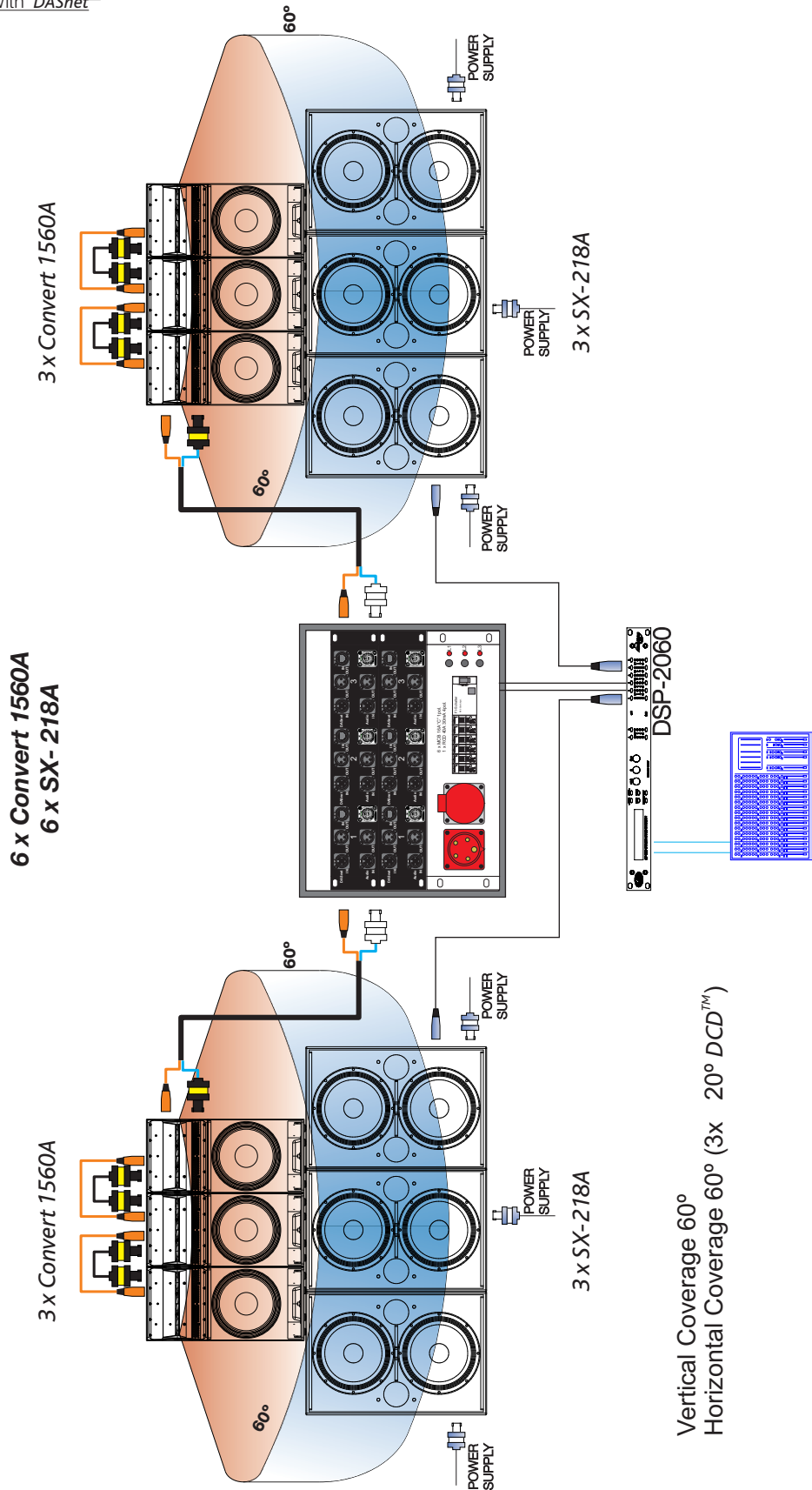

Note: In our website you can find more settings.

Example: With *DASnet™*

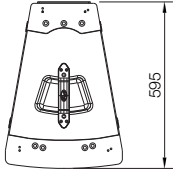

# LINE DRAWINGS

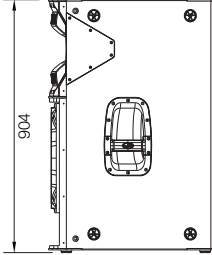
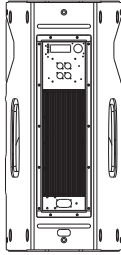
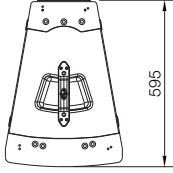
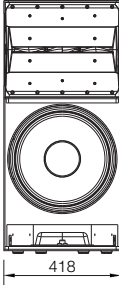
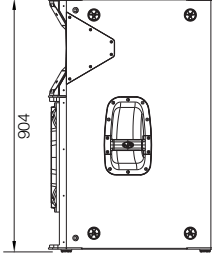
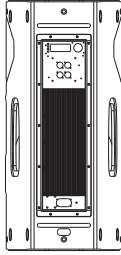
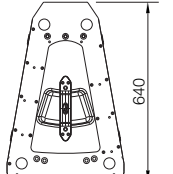
ALL DIMENSIONS IN MILIMETERS

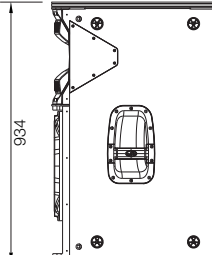
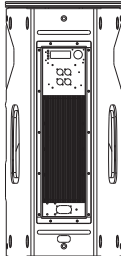
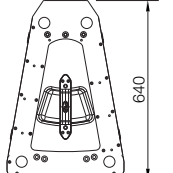
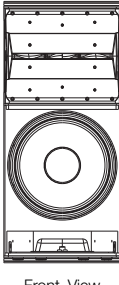
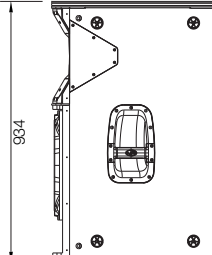
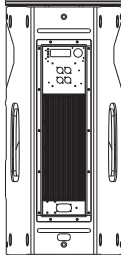
convert 1560A	 <p>Bottom View</p> <p>595</p>	 <p>Front View</p> <p>418</p>	 <p>Right View</p> <p>904</p>	 <p>Rear View</p>
convert 1590A	 <p>Bottom View</p> <p>595</p>	 <p>Front View</p> <p>418</p>	 <p>Right View</p> <p>904</p>	 <p>Rear View</p>
convert 1560RA	 <p>Bottom View</p> <p>640</p>	 <p>Front View</p>	 <p>Right View</p> <p>984</p>	 <p>Rear View</p> <p>418</p>
convert 1590RA	 <p>Bottom View</p> <p>640</p>	 <p>Front View</p>	 <p>Right View</p> <p>984</p>	 <p>Rear View</p> <p>418</p>

## AMPLIFIER

### Description

#### 1) INPUT :

XLR-type input signal connector. This is a balanced connector just like the LOOP THRU connector with the following pin assignments:

- 1 =GND (ground).
- 2 =(+ ) Non inverted input.
- 3 =(-) Inverted input.

#### 2) LOOP THRU :

XLR-type output signal connector for connecting several units together and sending them all the same signal.

#### 3) IN :

RJ45 connector for *DASnet™* input.

#### 4) OUT :

RJ45 connector for *DASnet™* output, for connecting several units together and sending them all the same signal.

#### 5) ON :

Green LED indicates that the unit is ON.

#### 6) IDENTIFY/COMMS :

The Orange LED is flashing when IDENTIFY is pressed (to identify the unit) or when *DASnet™* communication is in use.

#### 7) SIGNAL/LIMIT :

Bi-color LED indicates signal presence, when LED is green, and that the limiter of amplifier is acting, when LED is red.

#### 8) AMP. PROTECT :

Red LED indicates that the protection of one or more

#### 9) DISPLAY :

The 2x16 display shows messages or data

#### 10) KEYBOARD :

keyboard with 5 buttons for setting or selecting amplifier mode.

#### 11) MODEL :

Label for *convert 1560A* or *convert 1590A* model.

#### 12) QR :

QR symbol to access the manuals via Internet connection.

#### 13) ID DASNET :

Identification number label of the unit for to use with *DASnet™* (more information in section: CHANGE OF CONFIGURATION). This information also appears when you turn ON the unit.

#### 14) AC INPUT :

PowerCon TRUE1 type Neutrik connector for mains. **Only use this equipment with an appropriate mains cord.**

#### 15) AC OUTPUT :

PowerCon TRUE1 type Neutrik connector for mains output. **Only use this equipment with an appropriate mains cord.**

#### 16) HEATSINK :

Be careful when in contact with radiator because it can be hot, although it never will reach a dangerous temperature.

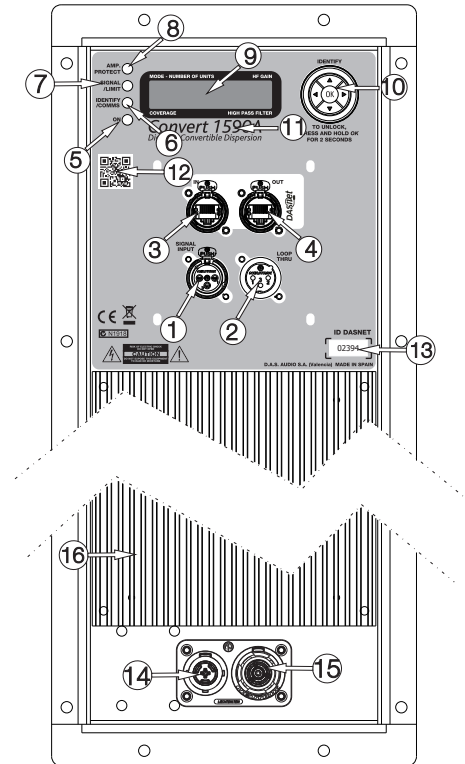

*convert 15A series*  
**Amplifier**

**NOTE:** When you turn ON the unit, the display shows the messages:



And, depending on the model, one of these two messages.



Finally, after a few seconds the screen turns off.



### **ON/OFF**

A sound system should be switched on sequentially. Switch on the self-powered units last in your sound system (switch on the subwoofer before the mid-high system). Switch on the sound sources such as CD players or turntables, then the mixer, then the processors, and finally the self-powered unit. If you have several units, it is recommended that you switch them on sequentially one at a time.

Follow the inverse order when switching off, turning self-powered units off before any other element in the sound system.

Disconnect the device by removing the mains connector from the mains socket. The mains connector and mains socket must always be freely accessible and never covered or blocked in any way. The mains cable can be detached from the device by disconnecting the Neutrik PowerCon TRUE1 connector. Always disconnect the device by removing the mains connector from the mains socket before detaching the mains cable at the Neutrik PowerCon TRUE1 connector. Power can be daisy chained via the PowerCon TRUE1 output connector (see details on product label).

**IMPORTANT:** Do not disconnect the unit while in use.

Ensure that the device is disconnected from the mains by observing that the ON LED is turned off. Please note that the ON LED can stay on for several seconds after the mains power has been disconnected.

### **Overload indicator**

This device has an indicator (SIGNAL/LIMIT LED) that lights with red color when the signal is excessive.

The indicator should not be lit continuously. This distorts the signal (quickly fatiguing your ears) and may damage the speakers. Therefore, it is recommended that you never work with this LED on; at most it should blink only occasionally.

### **Equalisation**

The unit does not need extreme settings of equalisation to produce quality sound. Avoid high levels of gain on the equalisers. Gain values above +3 dB on a console's EQ are not recommended.

### **Overheating**

This equipment does not normally overheat during normal conditions of use. When overheating occurs, the unit protects itself. You should then find out why and if necessary contact an authorised dealer for technical assistance.

Normally it is enough just to let the unit cool down after you have corrected the problem so that the system functions properly again.

The amplifier is equipped with fan and heatsink to maintain the correct operating temperature.

Keep grilles clean and dust-free.

Do not block or obstruct in any way the air entrance or exit while the equipment is in use.

Air circulates from the bottom to the top of the amplifier.

### **Low mains voltage**

If mains voltage falls below the shutdown voltage for the unit, it will stop playing. When acceptable levels are regained, the unit will switch back on automatically.

The unit accept, automatically, 230Vac or 115Vac ranges for working.

The values of voltage for de nominal ranges are: From 90Vac to 125Vac for 115Vac range, or from 180Vac to 250Vac for 230Vac range.

Therefore the current consumed by 115Vac range is double that of 230Vac range, to achieve the same acoustic power level.

For 230Vac range, the current consumed is 3A, with Pink Noise and giving 1/3 Nominal Power.

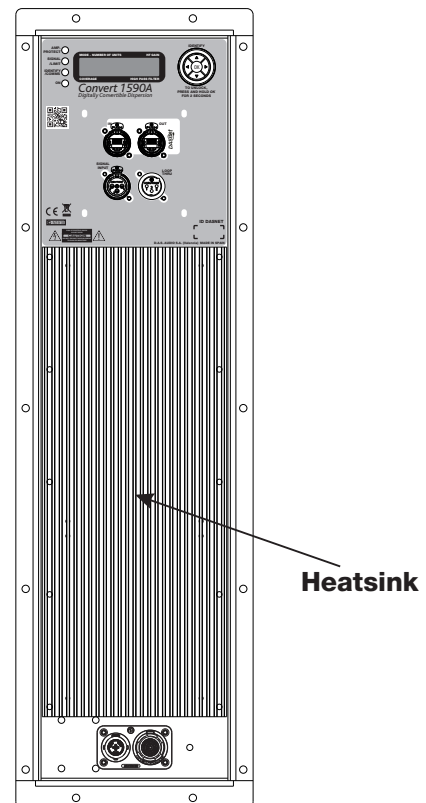

**Full image amplifier**



## Troubleshooting

PROBLEM	CAUSE	SOLUTION
No sound from the unit. The SIGNAL LED does not light up.	<p>1 – The signal source is sending no signal.</p> <p>2 – Defective cable.</p> <p>3 - The amplifier has overheated.</p>	<p>1 – Check that the mixer or sound source is sending signal to the UNIT.</p> <p>2 – Check that the cable from the sound source to the UNIT is connected correctly. Replace the cable if defective.</p> <p>3 - Allow the unit to cool down for some minutes and it will function again. Check the main output level of the mixer or channel gains since the unit will have been functioning with excessive levels.</p>
Full power cannot be obtained. The LIMIT LED never lights up.	The signal source does not have a hot enough output.	If using a mixer, use the balanced output if available. Use a professional mixer with a hotter output.
Sound is distorted. The LIMIT LED is not on, or only lights up occasionally.	The mixer or signal source is distorting.	Turn mixer channel gains down. Check that none of your signal sources are distorting.
Sound is distorted and very loud and LIMIT LED lights up.	The system is overloaded and has reached maximum power.	Turn down the mixer's output.
Hum or buzz when a mixer is connected to the unit.	<p>1.– The console probably has un-balanced outputs. You may be using an incorrect un-balanced to balanced cable.</p> <p>2.– The mixer and the powered speaker are not plugged into the same mains outlet.</p> <p>3.– The audio signal cable is too long or too close to an AC cable</p>	<p>1.– Read the appendix of this manual to make a correct un-balanced to balanced cable.</p> <p>2.– Connect the mixer and the unit to the same mains outlet.</p> <p>3.– Use a cable that is as short as possible and/or move the audio signal cable away from mains cables.</p>
Hum or buzz when using lighting controls in the same building.	<p>1.– The audio signal cable is too long or too close to the lighting cable.</p> <p>2.– On a sound system with three-phase AC, the lighting equipment and the UNIT are connected to the same phase.</p>	<p>1.– Move the audio signal cable away from lighting cables. Try to find out at what point the noise is leaking into the system.</p> <p>2.– Connect the sound system to a different phase than the lights. You may need the help of an electrician.</p>
The ON LED does not light up when the mains connector is connected and the unit is switched to ON.	<p>1.– Bad or loose AC connection to the UNIT or the mains outlet.</p> <p>2 – Faulty AC cable.</p> <p>3 – Blown Fuse (internal).</p> <p>4 - The mains voltage is out of range.</p>	<p>1.– Check your connections.</p> <p>2.– Check the cables, connectors and AC power with a suitable mains tester.</p> <p>3.- Replace the internal blown fuse for another of the same type and size.</p> <p>4.- If the multimeter determines that the mains voltage is out the range, you may need the assistance of an electrician to find an appropriate solution.</p>

## CHANGE OF CONFIGURATION

The unit, *convert 1560A* or *convert 1590A*, has default settings from the factory. We can change some default set parameters. The firmware described here is version 2.60.

However, parameters such as gain and delay can be changed only by *DASnet™*.

As indicated on the back label of the unit to unlock, press and hold 'OK' for 2 seconds, until the arrows cover the entire screen and then we can access the treble gain menu, or high-pass filter menu, etc, to make changes.

From factory, the unit *convert 1560A* has default settings:



While the unit *convert 1590A* has default settings:

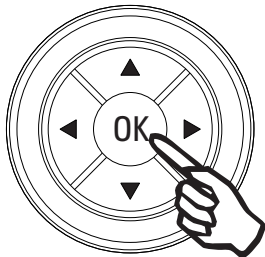

**TO UNLOCK,  
PRESS AND HOLD OK  
FOR 2 SECONDS**

If we press and hold 'OK' for 2 seconds, until the arrows cover the entire screen,



We will access the menus to change the gain treble, or high-pass filter, or others default parameters.

First shown on the screen:



And pressing the arrows indicated (**right** or **left**), you can go to other menus,

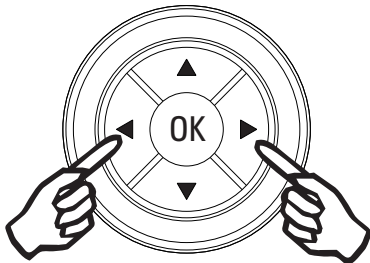

To access, simply click on 'OK'. Thus, in the first menu, 'Configuration', we can choose between the behavior of the unit as a point source (the default) or curved source, simply by pressing the **down** arrow and click 'OK', or with **up** arrow, to return to the previous menu.

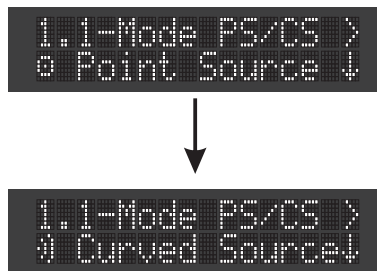
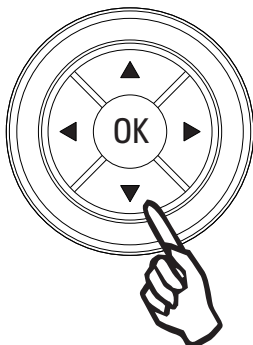

As can be seen, by pressing the **down** arrow on the last option, the menu returns to the first option. This feature occurs in the other menus as well.

If we have chosen point source, pressing the **right** arrow, we move on to a second menu.

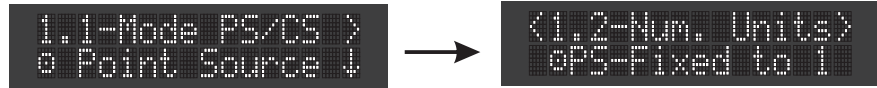
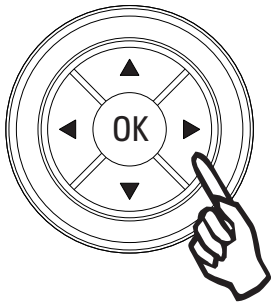

The absence of a down arrow indicates that an option is fixed, no more alternatives than 1 unit.

However, if we choose curved source, pressing the **right** arrow, we move on to a second menu where you can select from 1 to 4 units (default 1 unit).

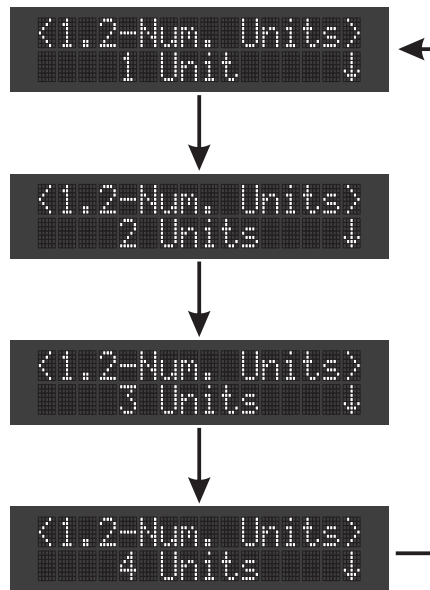
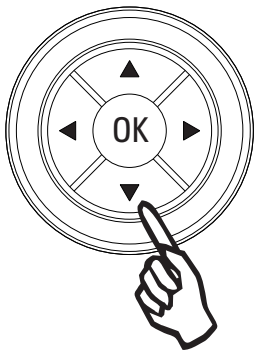
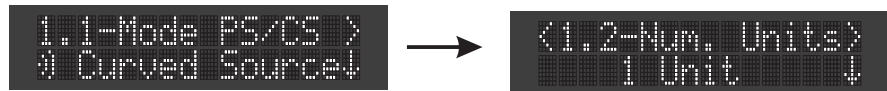
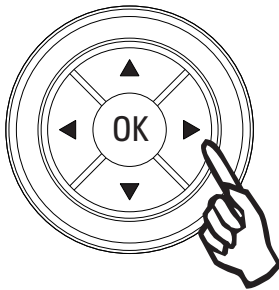

Press 'OK' for exit.

Also, if you press on the **right** arrow, we go to a new menu where you can choose the treble attenuation if desired (default is attenuated: 0 dB).

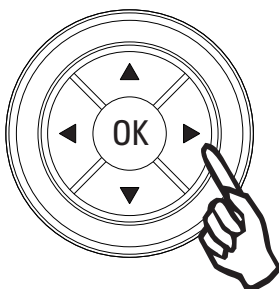

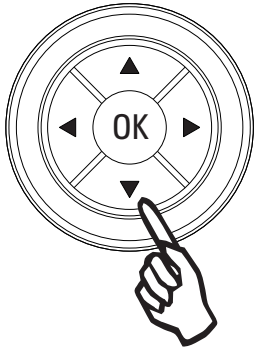

```
<1.3-HF Gain >
      0 dB      ↓
```

```
<1.3-HF Gain >
      -3 dB     ↓
```

```
<1.3-HF Gain >
      -6 dB     ↓
```

Press 'OK' for exit.

Also, if you press on the **right** arrow, we go to a new menu where you can choose a high-pass filter or not (default: OFF).

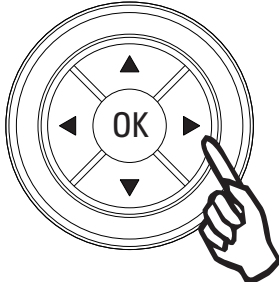

```
<1.4-HighPass >
      OFF       ↓
```

```
<1.4-HighPass >
      65 Hz     ↓
```

```
<1.4-HighPass >
      80 Hz     ↓
```

```
<1.4-HighPass >
      100Hz     ↓
```

Press 'OK' for exit.

If you press on the **right** arrow, we go to other menu. Afterwards, we can go to the **left** arrow only or exit.

Also, if the menu shows 'Configuration' we go to the menu 'Utilities' by pressing the **right** arrow. If you press 'OK', we go to this menu.

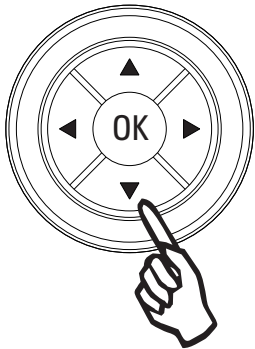

```
1-Configuration >
```



```
2-Utilities >
```

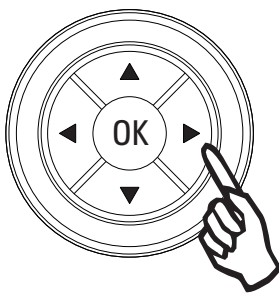

In this firmware version, this menu can replace only default parameters of the unit (including the gain to 0 dB and the delay to 0 ms). If you press and hold 'OK', until the arrows cover the lower half of the screen, the display will show this:

```
2.1- Restore
Default Parans
```



```
2.1- Restore
>>>>>>>>>>>>>>>>
```



```
Restoring
Default Parans
```

Finally, the display will show the default parameters.

*convert 1560A*

```
oPS-1U |HF: 0dB
↑30°↓30°|HP: OFF
```

*convert 1590A*

```
oPS-1U |HF: 0dB
↑45°↓45°|HP: OFF
```

Finally, if the menu shows 'Utilities' we go to the menu 'Information' by pressing the **right** arrow. If you press 'OK', we go to this menu.

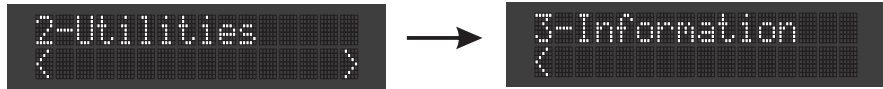
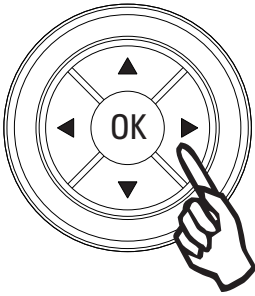

Then, automatically, the display will show the information of the unit, without pressing any buttons.

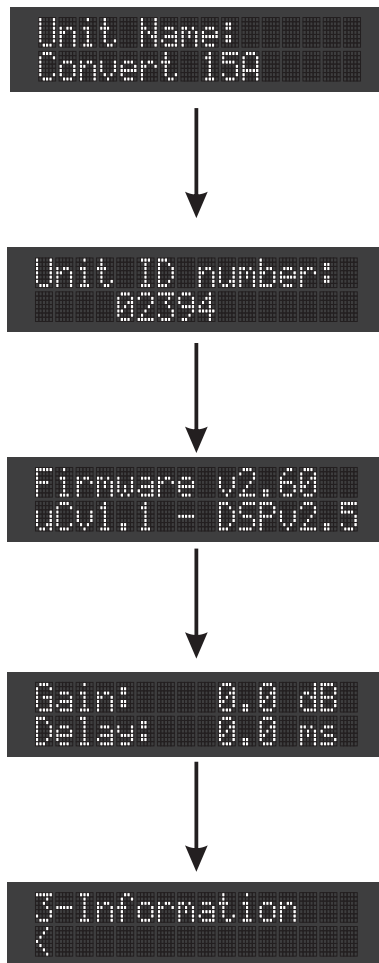

And will automatically stop once the last screen is reached. Press 'OK' to repeat the sequence.

## SPECIFICATIONS

Model	convert 1560A / 1560RA	convert 1590A / 1590RA
<b>Nominal LF Amplifier Power</b>	2000 W <sub>peak</sub> –1000W <sub>continuous</sub>	2000 W <sub>peak</sub> –1000W <sub>continuous</sub>
<b>Nominal HF Amplifier Power</b>	(1000 + 1000) W <sub>peak</sub> (500 + 500) W <sub>continuous</sub>	(1000 + 1000) W <sub>peak</sub> (500 + 500) W <sub>continuous</sub>
<b>Input Type</b>	Balanced Differential Line	Balanced Differential Line
<b>Input Impedance</b>	Line: 20 kohms	Line: 20 kohms
<b>Sensitivity</b>	Line:1.95 V (+8 dBu)	Line:1.95 V (+8 dBu)
<b>Frequency Range (-10 dB)</b>	50 Hz – 20 kHz	50 Hz – 20 kHz
<b>Rated Maximum Peak SPL at 1 m</b>	138 dB	138 dB
<b>Nominal -6 dB Beamwidths</b>	---	---
<b>Curved Source</b>	60° x 20°	90° x 20°
<b>Point Source</b>	60° x 40°	90° x 40°
<b>Enclosure Material</b>	Birch Plywood	Birch Plywood
<b>Color/Finish</b>	Black ISO-Flex Paint	Black ISO-Flex Paint
<b>Transducers/Replacement Parts</b>	LF: 15GNR / GM 15G HF: 3 x M-60N / GM M-60	LF: 15GNR / GM 15G HF: 3 x M-60N / GM M-60
<b>Connectors</b>	Audio INPUT: Female XLR Audio LOOP THRU: Male XLR Audio+Data INPUT: EtherCon Audio+Data LOOP THRU: EtherCon AC INPUT: PowerCON TRUE1 AC OUTPUT: PowerCON TRUE1	Audio INPUT: Female XLR Audio LOOP THRU: Male XLR Audio+Data INPUT: EtherCon Audio+Data LOOP THRU: EtherCon AC INPUT: PowerCON TRUE1 AC OUTPUT: PowerCON TRUE1
<b>AC Power Requirements</b>	5.0 A, 115 V, 50 Hz/60 Hz	5.0 A, 115 V, 50 Hz/60 Hz
<b>1/3 Power (Pink Noise)</b>	2.5 A, 230 V, 50 Hz/60 Hz	2.5 A, 230 V, 50 Hz/60 Hz
<b>Dimensions (H x W x D)</b>	89.3 x 41.7 x 59 cm 35.6 x 16.45 x 23.4 in	89.3 x 41.7 x 59 cm 35.6 x 16.45 x 23.4 in
<b>(RA version with rigging)</b>	93.6 x 41.8 x 64 cm 37.2 x 16.45 x 25.2 in	93.6 x 41.8 x 64 cm 37.2 x 16.45 x 25.2 in
<b>Weight</b>	47 kg (103.4 lb)	47 kg (103.4 lb)
<b>(RA version with rigging)</b>	58.5 kg (128.7 lb)	58.5 kg (128.7 lb)

Product improvement through research and development is an ongoing process at **D.A.S.**  
All specifications are subject to change without notice.

## RIGGING SYSTEM

### **Warning**

This manual doesn't contain all needed information for flying *convert 15A* systems. The present manual due to the numerous combinations possible, only contains a resume of the elements and the safety precautions.

Please, see the **Rigging Manual** for more information.

To perform any operations related to flying the system, read the **Rigging Manual** first, and act on the warnings and advice given. The goal is to allow the user to become familiar with the mechanical elements required to fly the acoustic system, as well as the safety measures to be taken during set-up and teardown.

Only experienced installers with adequate knowledge of the equipment and local safety regulations should fly speaker boxes.

It is the user's responsibility to ensure that the systems to be flown (including flying accessories) comply with state and local regulations.

The working load limits in this manual are the results of tests by independent laboratories. It is the user's responsibility to stay within safe limits. It is the user's responsibility to follow and comply with safety factors, resistance values, periodical supervisions and warnings given in this manual.

To this date, there is no international standard regarding the flying of acoustic systems. However, it is common practice to apply 5:1 safety factors for enclosures and static elements.

For slings and elements exposed to material fatigue due to friction and load variation the following ratios must be met; 5:1 for steel cable slings, 4:1 for steel chain slings and 7:1 polyester slings. Thus, an element with a breaking load limit of 1000 kg may be statically loaded with 200 kg (5:1 safety factor) and dynamically loaded with 142 Kg (7:1 safety factor).

When flying a system, the working load must be lower than the resistance of each individual flying point in the enclosure, as well as each box.

Hanging hardware should be regularly inspected and suspect units replaced if in doubt.

**This is important to avoid injury and absolutely no risks should be taken in this respect.**

It is highly recommended that you implement an inspection and maintenance program on flying elements, including reports to be filled out by the personnel that will carry out the inspections.

Local regulations may exist that, in case of accident, may require you to present evidence of inspection reports and corrective actions after defects were found.

**It is the user's responsibility to ensure that the systems to be flown (including flying accessories) comply with state and local regulations.**

Product improvement by means of research and development is on going at **D.A.S.** Specifications are subject to change without notice.

### **Hardware and accessories**

The *convert 15A* systems of **DAS Audio** allow four basic forms for rigging.

Two forms, if you need an horizontal or vertical mounting and two forms more, if you use the model '**-A**' or '**-RA**'.

On 20 page, you can consult the four basic combinations for the *convert 15A* systems.

The *convert 15A* enclosure is constructed using birch plywood and finished with the ISO-flex black paint providing excellent protection and durability.

The 20° trapezoidal shape of the *convert 15A* enclosure allows for tightly packed arrays with minimal high frequency interaction.

As an aid when stacking the enclosures in vertical arrays, rubber locators on the side panels match with fitting points on the surfaces of adjacent cabinets preventing slippage.

The optional *InterLox™* rigging system can be used to quickly and safely assemble tight-packed vertical or horizontal curved-source arrays. M-10 threaded rigging points are provided for use in permanent installation.

Please, see **Rigging Manual** for more information.

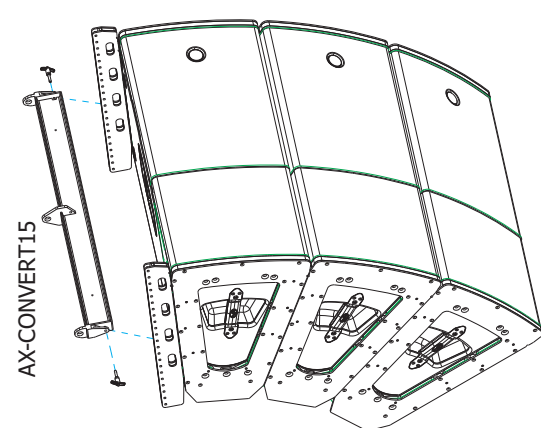
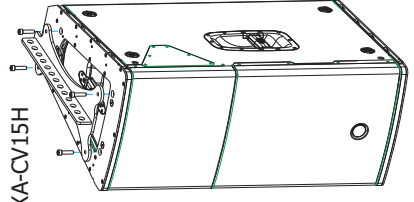
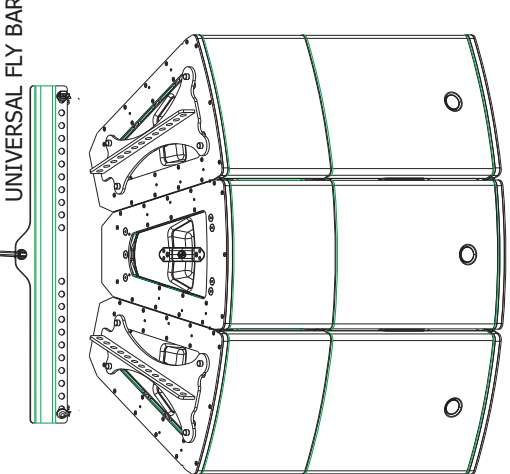
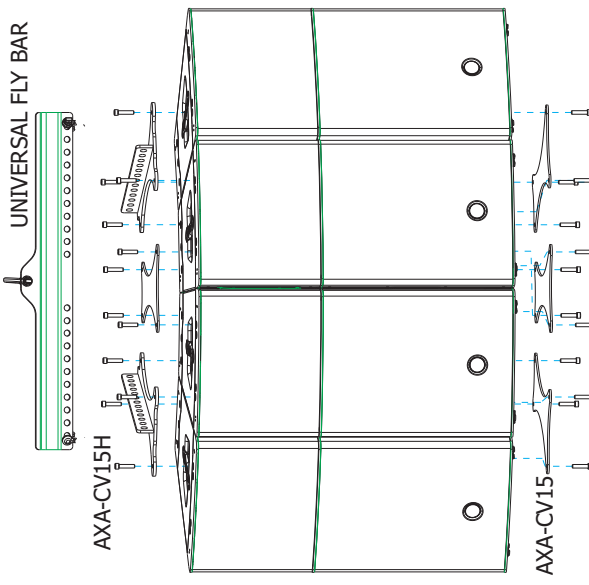
<p>VERTICAL ARRAY</p>	<p>AX-CONVERT15</p> 	<p>CONVERT 1560RA CONVERT 1590RA</p>
<p>AXA-CV15H</p> 	<p>HORIZONTAL ARRAY</p> <p>UNIVERSAL FLY BAR</p> 	<p>AXA-CV15</p> 



## APPENDIX: Line connections: unbalanced and balanced

There are two basic ways to transport an audio signal with microphone or line level:

**Unbalanced line:** Utilising a two conductor cable, it transports the signal as the voltage between them. Electromagnetic interference can get added to the signal as undesired noise. Connectors that carry unbalanced signals have two pins, such as RCA (Phono) and 1/4" (6.35mm, often referred to as jack) mono. 3 pin connector such as XLR (Cannon) may also carry unbalanced signals if one of the pins is unused.

**Balanced line:** Utilising a three conductor cable, one of them acts as a shield against electromagnetic noise and is the ground conductor. The other two have the same voltage with respect to the ground conductor but with opposite signs. The noise that cannot be rejected by the shield affects both signal conductors in the same way. At the device's input the two signals get summed with opposite sign, so that noise is cancelled out while the programme signal doubles in level. Most professional audio devices use balanced inputs and outputs. Connectors that can carry balanced signal have three pins, such as XLR (Cannon) and 1/4" (6.35mm) stereo.

The graphs that follow show the recommended connection with different types of connectors to balanced processor or amplifier inputs. The connectors on the left-hand side come from a signal source, and the ones on the right hand side go to the inputs of the processor or amplifier. Note that on the unbalanced connectors on the left-hand side, two terminals are joined in side the connector. If hum occurs with balanced connections, try disconnecting the sleeve (ground) on the input connector. Note that the illustrations show what should be connected to what, but that pin locations on an actual XLR connector are different. Also, pin 2 hot is assumed on XLR connectors.

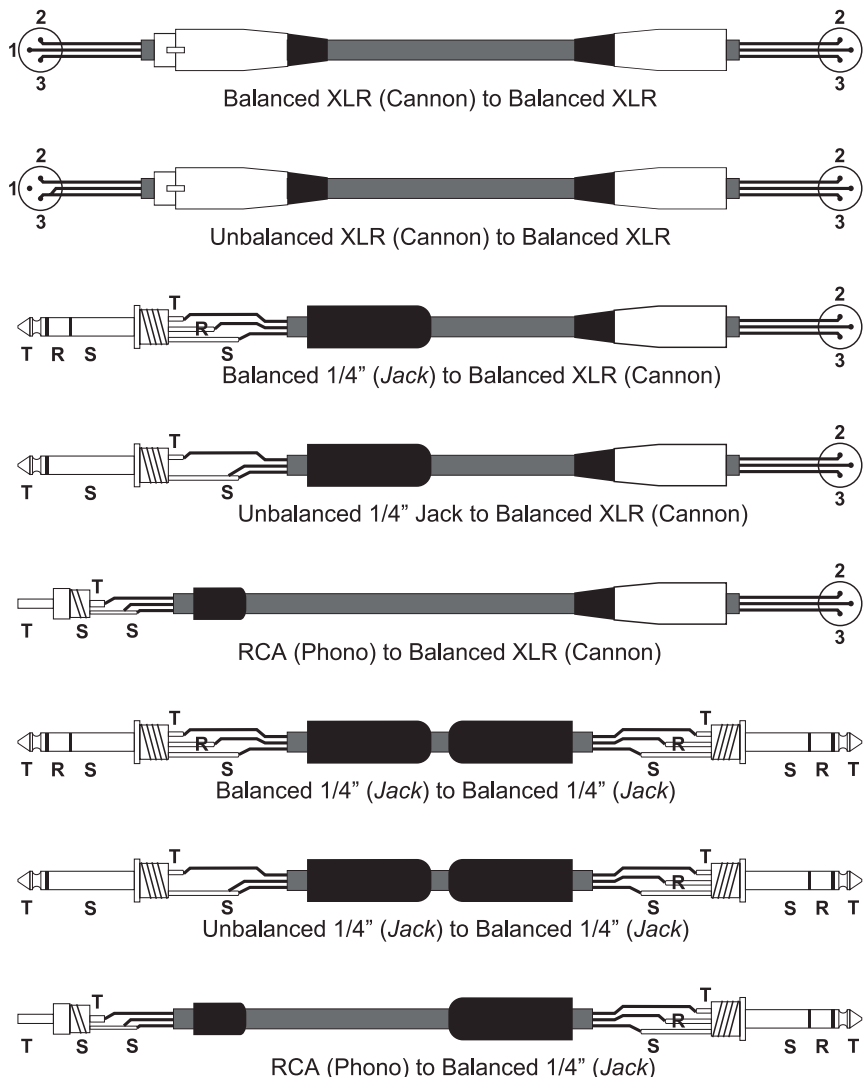

[www.dasaudio.com](http://www.dasaudio.com)



**D.A.S. AUDIO, S.A.**

C/ Islas Baleares, 24  
46988 Fuente del Jarro  
Valencia, SPAIN  
Tel. 96 134 0525  
Tel. Intl. +34 96 134 0860  
Fax 96 134 0607  
Fax Intl. +34 96 134 0607

**D.A.S. AUDIO OF AMERICA, INC.**

Sunset Palmetto Park  
6816 NW 77th Court.  
Miami, FL. 33166 - U.S.A.  
TOLL FREE: 1-888DAS4USA  
Tel. +1 305 436 0521  
Fax +1 305 436 0528

**D.A.S. AUDIO ASIA PTE. LTD.**

25 Kaki Bukit Crescent #01-00/02-00  
Kaki Bukit Techpark 1  
Singapore 416256  
Tel. +65 6742 0151  
Fax +65 6742 0157