

DS-115

Dynamics

series



FEATURES

- » 2-way vented loudspeaker system
- » 15" cone speaker
- » 1" compression driver with Neodymium magnet
- » 350 W power handling
- » Polypropylene enclosure

SPECIFICATIONS

RMS (Average) Power Handling^a:	350 W
Program Power Handling^b:	700 W
Peak Power Handling^c:	1400 W
On-axis Frequency Range^d:	50 Hz - 19 kHz
Nominal Impedance:	8 Ω
Minimum Impedance:	6.7 Ω (at 39 Hz)
On-axis Sensitivity 1W / 1 m^e:	100 dB SPL
Rated Peak SPL at Full Power:	131 dB
Nominal -6 dB Beamwidths^f:	90° Horizontal
(average, 500 Hz to 8 kHz)	60° Vertical
Speech Coverage Angles^g:	100° Horizontal x 75° Vertical
Enclosure Material:	High density mineral loaded polypropylene
Colour:	Black or white
Transducers/Replacement Parts:	Low: 15P/GM 15P High: M-5N/GM M-5
Connector:	2 paralleled NL4 Speakon, wired to ±1
Dimensions (H x W x D):	71 x 46 x 42 cm (28 x 18 x 16.5 in)
Weight:	18.6 kg (41 lbs)
Shipping Weight:	21 kg (46 lbs)
Accessories (optional):	TRD-2 adjustable tripod ANL-1, 4-piece M8 eyebolt/carabiner set AX-115 wall mounting bracket

INTRODUCTION

The D.A.S. DS-115 is a versatile high efficiency 2-way vented loudspeaker system.

APPLICATIONS

Intended for use in fixed and portable sound reinforcement, musical instruments, discos, clubs.

DESCRIPTION

The low end utilizes a high efficiency 15" low frequency speaker with 3" voice coil.

The low frequency section utilizes a 15" low frequency speaker with 3" voice coil. The high frequency section makes use of a Neodymium 1" exit compression driver with 1.75" titanium diaphragm, coupled to a constant directivity horn that is integral to the enclosure baffle.

Full use of high pressure injection moulding techniques has achieved a mineral loaded polypropylene cabinet of a very high density with minimum vibration. Computer assisted internal design provides extensive wall reinforcing for minimum vibration and solid bass. The complex enclosure shape allows for stage monitor use. Three integral handle facilitate carrying. For added resistance, a rugged steel grille protects the woofer.

MOUNTING

Nine M8 rigging points are built into the enclosure, allowing for comprehensive flying and mounting options. An integral 35 mm socket can be used for tripod use.

A range of optional accessories is available: mounting brackets, tripods and hanging rings provide flexible mounting options.

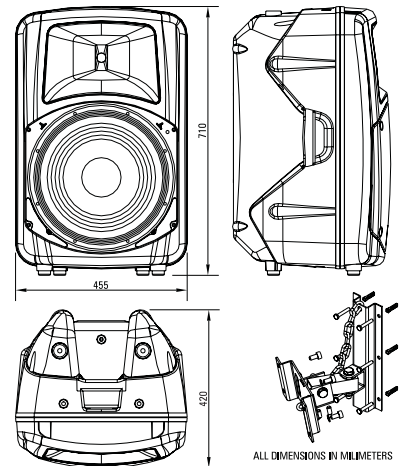

ALL DIMENSIONS IN MILLIMETERS

^a Based on a 2 hour test using a 6 dB crest factor pink noise signal bandlimited according to IEC 268-1 (1985). All power ratings are referred to the nominal impedance.

^b Conventionally 3 dB higher than the RMS measure, although this already utilizes a program signal.

^c Corresponds to the signal crests for the test described in^f.

^d As per IEC 268-5 (1989), re. a one octave band centred at 4 kHz. Half space anechoic.

^e In practice cable and connector impedance has to be added to all impedance values.

^f As per IEC 268-5 (1989), for the 2-10 kHz band.

^g Average of one-third octave band measures.

^h There is currently no standard method of averaging the beamwidth with frequency characteristics into a single meaningful figure, which impedes comparisons across manufacturers and very often even product lines. This, our own, criterion weighs the -6 dB coverage angles from one-octave bands according to their contribution to speech intelligibility.

One and one-third octave bands comply to ANSI S1.11-1986.

D.A.S.
SOUND PRODUCTS

FREQUENCY RESPONSE

Figure 1 shows the frequency response at 1 m of a unit radiating to a half space anechoic environment and driven by a 1 W (2.83 V) swept sine signal.

IMPEDANCE

Figure 2 shows impedance with frequency.

DISTORTION

Figure 3 shows the Second Harmonic Distortion (grey) and Third Harmonic Distortion (dotted) curves for a unit driven at 10% of its nominal power handling rating.

BEAMWIDTH

Figure 4 shows the -3, -6 and -10 dB horizontal (solid) and vertical (dashed) beamwidth with frequency curves. -6 dB ones are shown with thicker traces for clarity.

AXIAL DIRECTIVITY Q(R₀) AND DI

Figure 5 shows the above characteristics with frequency. Thin continuous and dashed lines show partial horizontal and vertical, respectively, characteristics.

POLAR RESPONSE

Figure 6 shows the one octave band horizontal (solid) and vertical (dashed) polars for the indicated frequencies. Full scale is 50 dB, 5 dB per division.

NOTES. 1.Frequency response: referred to 1 m; low end obtained through the use of near field techniques; one-third octave smoothed for correlation with human hearing. 2.In practice, cable and connector impedance need to be added. 3.Harmonic distortion components are not plotted beyond 20 kHz; near-field techniques used. 4.Directivity characteristics plotted with respect to frequency are the average within the one-third octave bands of center frequencies noted by the marks at the bottom of the graphs, but are joined up for display purposes. All other characteristics plotted vs. frequency use 1/24th octave resolution. Regions of less than 1 dB below goal level and sharp notches may be ignored when calculating beamwidths. 5.Directivity factor and index were computed from two degree resolution vertical and horizontal polars using sinusoidal weighting. 6.Polars were acquired by placing the unit on a computer controlled turntable inside our anechoic chamber. Measurement distance was 4 m.

Product improvement through research and development is a continuous process at D.A.S. Audio. All specifications subject to change without notice.

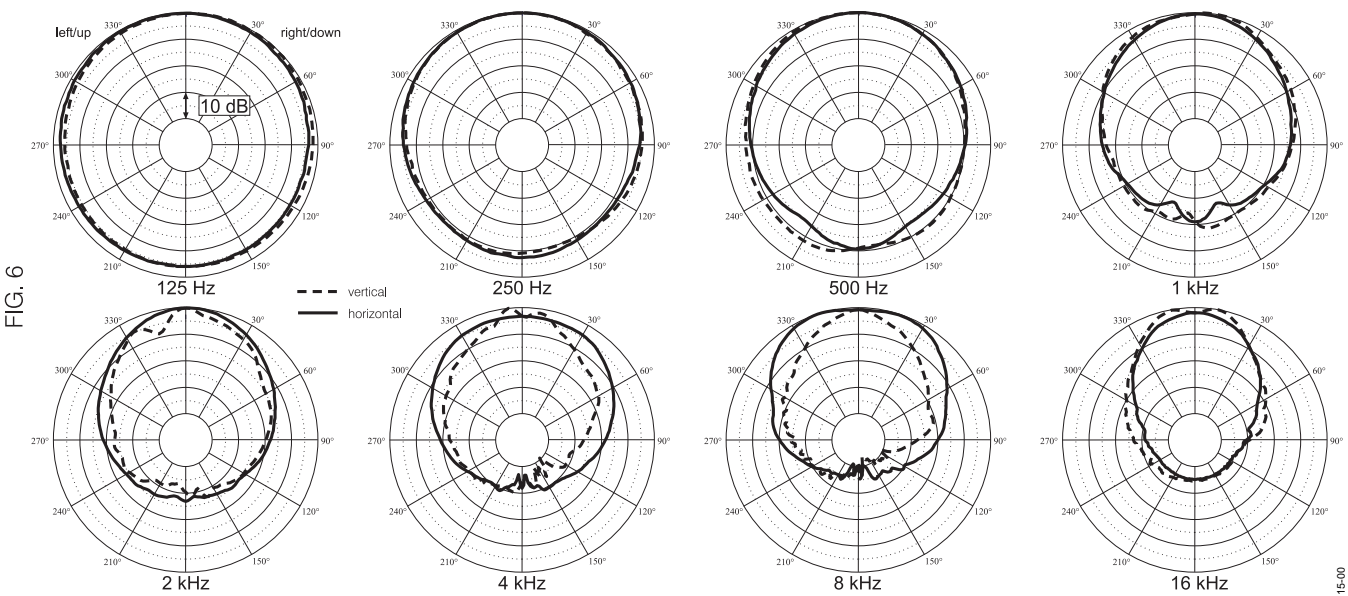
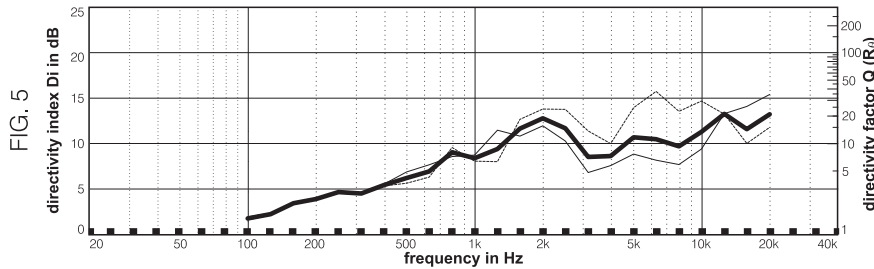
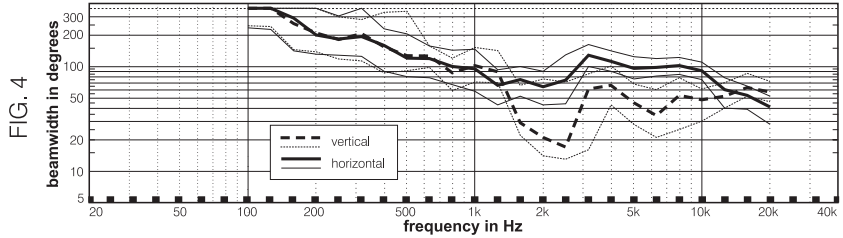
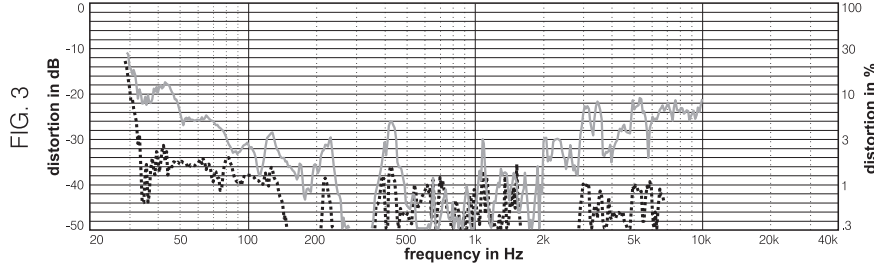
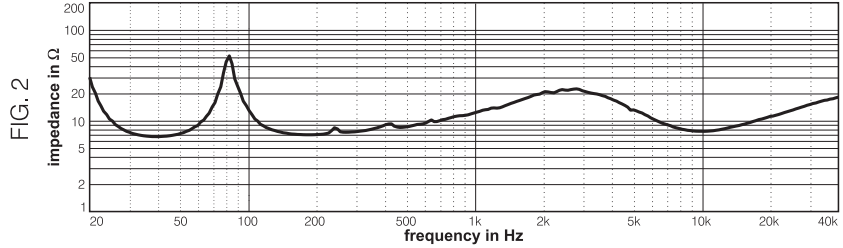
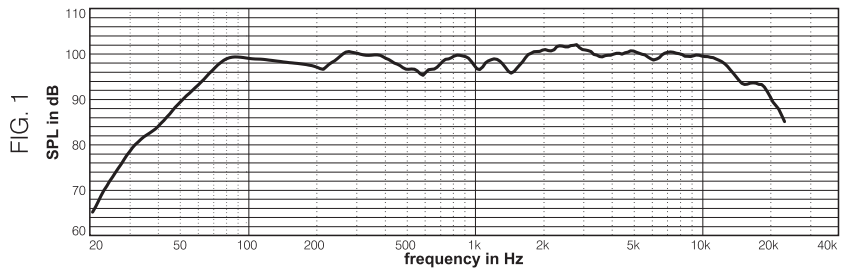

TE/da/115-00
03/03