

# User's Manual

# MX-20

2-CHANNEL DJ MIXER



[www.altoproaudio.com](http://www.altoproaudio.com)  
Version 1.0 November 2003

— English —

## SAFETY RELATED SYMBOLS



This symbol, wherever used, alerts you to the presence of un-insulated and dangerous voltages within the product enclosure. These are voltages that may be sufficient to constitute the risk of electric shock or death.



This symbol, wherever used, alerts you to important operating and maintenance instructions. Please read.



Protective Ground Terminal



AC mains (Alternating Current)



Hazardous Live Terminal

**ON:** Denotes the product is turned on.

**OFF:** Denotes the product is turned off.

### WARNING

Describes precautions that should be observed to prevent the possibility of death or injury to the user.

### CAUTION

Describes precautions that should be observed to prevent damage to the product.

## WARNING

### • Power Supply

Ensure that the mains source voltage (AC outlet) matches the voltage rating of the product. Failure to do so could result in damage to the product and possibly the user.

Unplug the product before electrical storms occur and when unused for long periods of time to reduce the risk of electric shock or fire.

### • External Connection

Always use proper ready-made insulated mains cabling (power cord). Failure to do so could result in shock/death or fire. If in doubt, seek advice from a registered electrician.

### • Do Not Remove Any Covers

Within the product are areas where high voltages may present. To reduce the risk of electric shock do not remove any covers unless the AC mains power cord is removed.

**Covers should be removed by qualified service personnel only.**

No user serviceable parts inside.

### • Fuse

To prevent fire and damage to the product, use only

the recommended fuse type as indicated in this manual. Do not short-circuit the fuse holder. Before replacing the fuse, make sure that the product is OFF and disconnected from the AC outlet.

### • Protective Ground

Before turning the product ON, make sure that it is connected to Ground. This is to prevent the risk of electric shock.

Never cut internal or external Ground wires. Likewise, never remove Ground wiring from the Protective Ground Terminal.

### • Operating Conditions

Always install in accordance with the manufacturer's instructions.

To avoid the risk of electric shock and damage, do not subject this product to any liquid/rain or moisture. Do not use this product when in close proximity to water.

Do not install this product near any direct heat source.

Do not block areas of ventilation. Failure to do so could result in fire.

Keep product away from naked flames.

## IMPORTANT SAFETY INSTRUCTIONS

Read these instructions

Follow all instructions

Keep these instructions. Do not discard.

Heed all warnings.

Only use attachments/accessories specified by the manufacturer.

### • Power Cord and Plug

Do not tamper with the power cord or plug. These are designed for your safety.

Do not remove Ground connections!

If the plug does not fit your AC outlet seek advice from a qualified electrician.

Protect the power cord and plug from any physical stress to avoid risk of electric shock.

Do not place heavy objects on the power cord. This could cause electric shock or fire.

### • Cleaning

When required, either blow off dust from the product or use a dry cloth.

Do not use any solvents such as Benzol or Alcohol. For safety, keep product clean and free from dust.

### • Servicing

Refer all servicing to qualified service personnel only.

Do not perform any servicing other than those instructions contained within the User's Manual.

## PREFACE

Dear Customer:

Thanks for choosing ▲LTO MX-20 2-CHANNEL DJ MIXER and thanks for choosing one of the results of ▲LTO AUDIO TEAM's work and researches.

For our ▲LTO AUDIO TEAM, music and sound are more than a job... It is a passion and an obsession!

We have been designing professional audio products for a long time in cooperation with some of the major brands in the world in the audio field.

Because we are convinced you are the most important member of ▲LTO AUDIO TEAM and the one confirming the quality of our job, we like to share with you our work and our dreams, paying attention to your suggestions and your comments.

Following this idea we create our products and we will create the new ones! From our side, we guarantee you and we will guarantee you also in future the best quality, the best fruits of our continuous researches and the best prices.

Our ▲LTO MX-20 2-CHANNEL DJ MIXER has extensive features i.e. 2 phono/line inputs; 1 microphone input; treble, middle and bass EQ on each channel; crossfader control etc., which are suitable for many other professional applications.

We would like to thank all the people who made the ▲LTO MX-20 2-CHANNEL DJ MIXER, especially to our designers and ▲LTO staff . It is their passion for music and professional audio that has made it possible for us to offer you, our most important team member, our continued support.

Thank you very much  
▲LTO AUDIO TEAM

# TABLE OF CONTENTS

<b>1. INTRODUCTION.....</b>	<b>4</b>
<b>2. FEATURE LIST.....</b>	<b>4</b>
<b>3. CONTROL ELEMENTS.....</b>	<b>5</b>
<b>3.1 The Top Cover</b>	
3.1.1 The CHANNEL Section	
3.1.2 The MIC/MAIN Section	
3.1.3 The PFL (pre fader level) Section	
3.1.4 The LEVEL METER Section	
3.1.5 The CROSSFADER Section	
<b>3.2 The Front Panel</b>	
3.2.1 MIC IN Jack	
3.2.2 The PHONE OUT Jack	
<b>3.3 The Rear Panel</b>	
3.3.1 AC Inlet and Fuse Holder	
3.3.2 POWER Switch	
3.3.3 MAIN OUT	
3.3.4 INPUT	
3.3.5 GND Screw	
<b>4. TECHNICAL SPECIFICATIONS.....</b>	<b>10</b>
<b>5. SYSTEM BLOCK DIAGRAM.....</b>	<b>11</b>
<b>6. WARRANTY.....</b>	<b>12</b>

## 1. INTRODUCTION

What a great DJ mixer you have just bought. Your MX-20 is packed with features such as 2 turntable inputs, 2 line inputs, 1 microphone input, 3 bands equaliser and gain control for per channel.

Through your MX-20 is very easy to operate. Please go through this manual carefully and you will get the best out of your MX-20.

## 2. FEATURE LIST

- 5 inputs: 2 phono and 2 line inputs, 1 microphone input
- 2 master output through RCA connector, headphone output via 1/4" TRS jack
- Crossfader control
- PFL switch
- Gain control on each channel
- Treble, middle and bass equalizer on each channel
- Highly accurate 10-segment bar-graph meters

### 3. CONTROL ELEMENTS

#### 3.1 The Top Cover

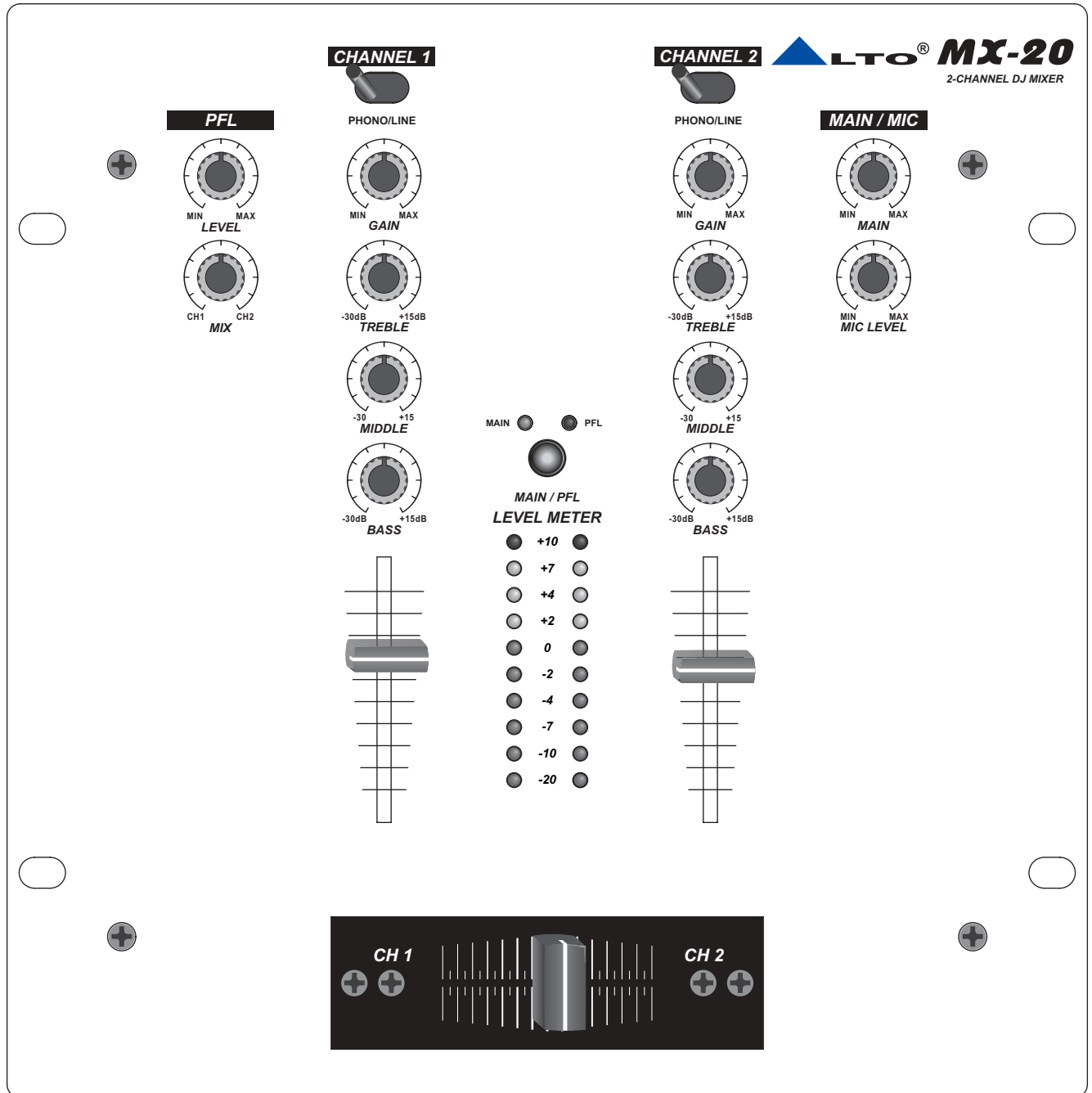

### 3.1.1 The CHANNEL Section

#### - PHONO / LINE Switch 1

This switch is available on both input channels. You shall use the LINE position for all high level audio signals such as CD Players, DAT, MD, etc.. You shall use the PHONO position to connect the turntables.

#### - The GAIN Control 2

Via this knob you will adjust the input level. Do not turn this control too much clockwise or you will overload the channel but do not turn it too much counterclockwise or you will generate background hiss.

#### - The EQUALIZER Control

Each input channel is provided with 3 bands equalizer: Treble 3, Middle 4 and Bass 5, and you can adjust the gain range of each from -30dB to +15dB.

#### - The PROGRAM Fader 6

There is a Program Fader available on both channels. These faders are used to adjust the overall level of the input channels.

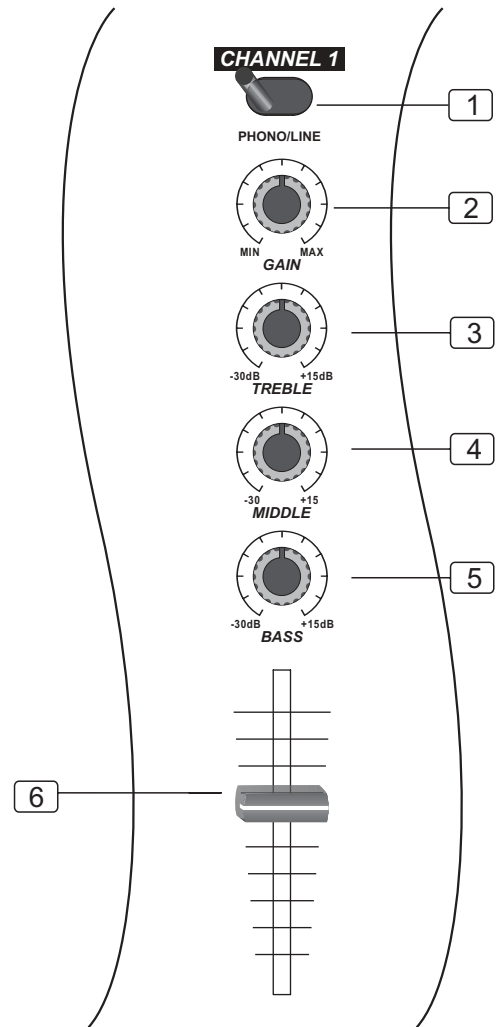

### 3.1.2 The MIC/MAIN Section

#### - MAIN LEVEL Control 7

This knob controls the overall output volume.

#### - MIC LEVEL Control 8

You can adjust the level of the microphone signal via this control.

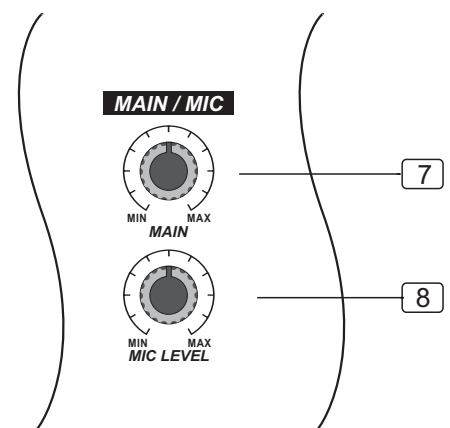

### 3.1.3 The PFL (pre fader level) Section

When you connect a headphone to your MX-20 you have the chance of pre-listening the audio signal before the signal reach the main output.

- **LEVEL Control** 9

This knob will adjust the volume of the headphone signal.

- **The MIX Control** 10

Through this control, you can mix the signal between CH1 and CH2.

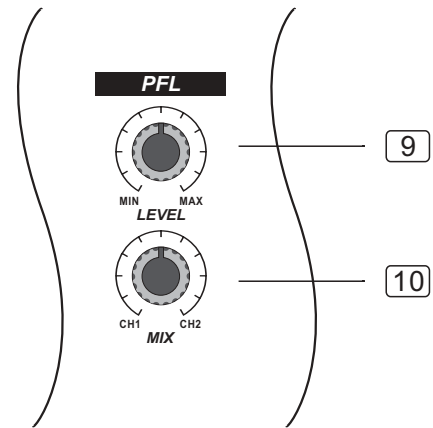

### 3.1.4 The LEVEL METER Section

- **MAIN/PFL Switch** 11

When this switch is in MAIN function (MAIN LED on) the level Meter will display the output level of the left and right channels;

When this switch is in PFL function (PFL LED on) the level Meter will display the PFL headphone signal: channel 1 on left LED meter and channel 2 on right LED meter.

- **LEVEL METER** 12

This 10 segments LED's Meter will read the signal selected by the MAIN/PFL switch. Please see following.

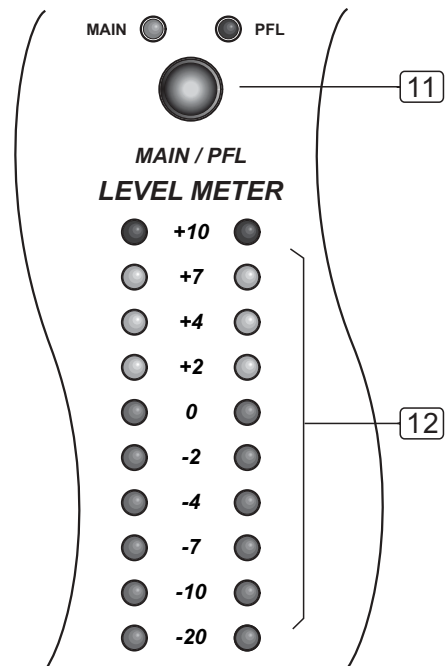

### 3.1.5 The CROSSFADER Section

- **The FADER Control** 13

Through this crossfader you can fade in between channel 1 and channel 2. The crossfader on your MX-20 is User replaceable.

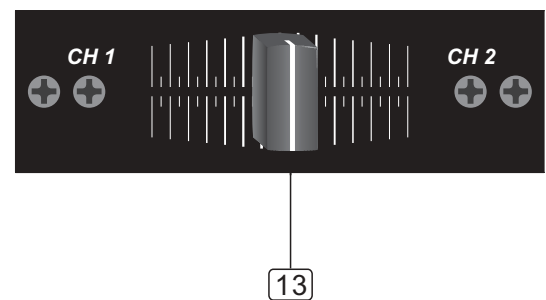



### 3.2 The Front Panel



#### 3.2.1 MIC IN Jack

14

This input will accept any unbalanced low impedance microphone. The functions of the microphone will be controlled by the MIC/MAIN section on the top panel.

#### 3.2.2 The PHONE OUT Jack

15

This input will accept a standard headphone with a 1/4" stereo jack. Through the PFL section on top panel, you can adjust the headphone signal properly.

### 3.3. The Rear Panel

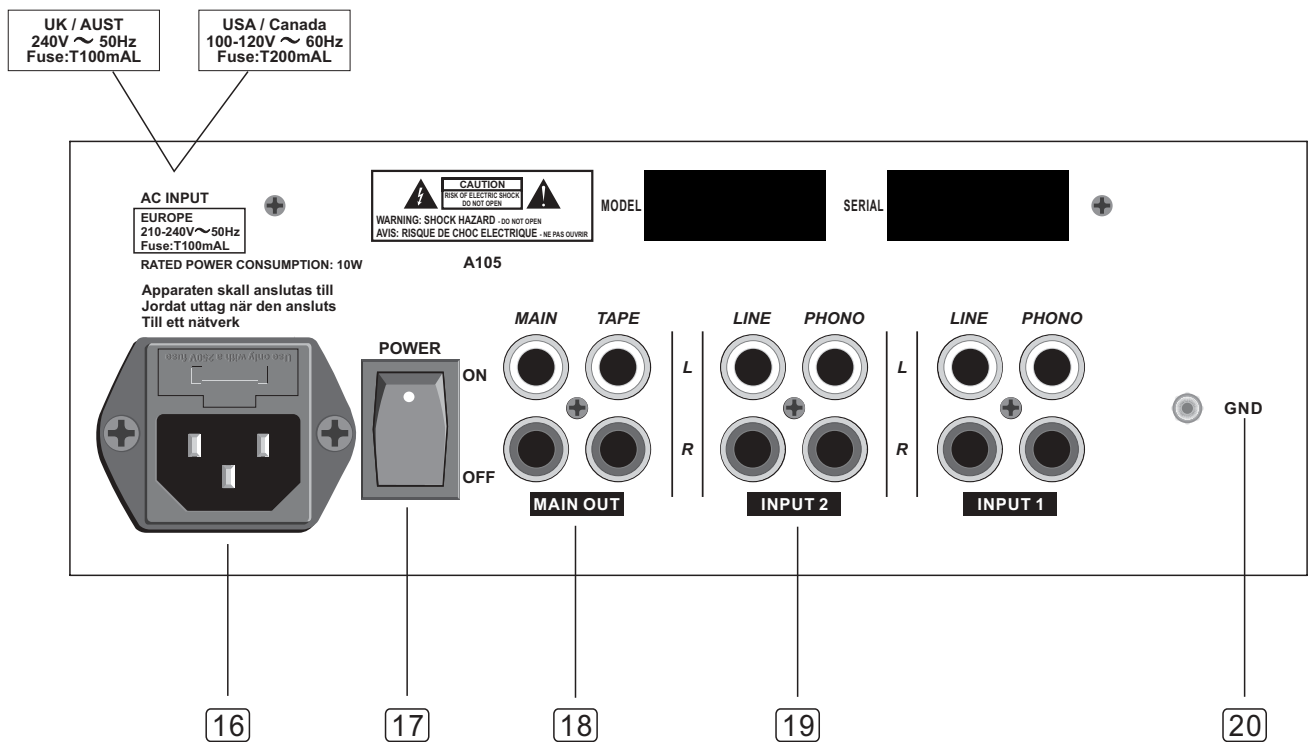

### 3.3.1 AC Inlet and Fuse Holder 16

This connector is meant for the connection of the supplied power cord. Please check the voltage accepted by the unit and the voltage available from your AC sockets before connecting the unit to the mains.

### 3.3.2 POWER Switch 17

This switch turns the Mixer ON and OFF.

### 3.3.3 MAIN OUT 18

Both MAIN output and TAPE output are RCA type connectors. Through the MAIN output you can connect your MX-20 to an amplifier. Through the TAPE output you can connect your MX-20 to a tape recorder.

### 3.3.4 INPUT 19

- PHONO input: Both Channels feature PHONO inputs including RIIA preamplifier for turntable. PIN (RCA) jacks shall be used to connect the turntable.
- LINE input: Through these RCA type sockets you can connect a CD player, an MD player or any other high level device such as Tape Recorder, DAT, etc,

**Important Notice:** If you wish to connect LINE level devices into the LINE/PHONO input, make sure that the LINE/PHONO switch is on LINE position otherwise the sensitive RIIA preamplifier built-in in the Phono input will be overloaded and will produce distortion.

### 3.3.5 GND Screw 20

This grounding connection is provided for your turntables.

#### 4. TECHNICAL SPECIFICATIONS

<b>INPUTS</b>		
	Phono Inputs 1 and 2	48dB gain@1kHz,unbalanced
	Line Inputs 1 and 2	8dB gain, unbalanced
	Mic Input	58dB gain, servo - balanced
<b>OUTPUTS</b>		
	Headphones	typically 125mW@ 1% THD
	Main Out	max +21dBu
	Tape Out	typically 0dBu
<b>GENERAL</b>		
	Stereo Bass	+15dB/ - 30dB
	Stereo Middle	+15dB/ - 30dB
	Stereo Treble	+15dB/ - 30dB
	Input Gain Adjustment	- 20dB - +6dB ( $\pm 3$ dB)
	Signal - to - Noise ratio (S/N)	>85dB (LINE)
	Distortion (THD)	<0.1%
	Frequency Response	20Hz - 20KHz ( $\pm 2$ dB)
<b>POWER SUPPLY</b>		
	Connector type	3 - pole IEC, grounded
	Mains Voltage	USA / Canada 100 - 120V~, 60Hz
		Europe 210 - 240V~, 50Hz
		U.K. / Australia 240V~, 50Hz
	Rated Power Consumption	10W
	Fuse	100 - 120V~ : T200mAL
		210 - 240V~ : T100mAL
<b>PHYSICAL</b>		
	Dimension	221.5(L)×245(W)×76.6(H)mm (8.7"×9.6"×3.0")
	Weight	2.6Kg (5.73lb)

# 5. SYSTEM BLOCK DIAGRAM

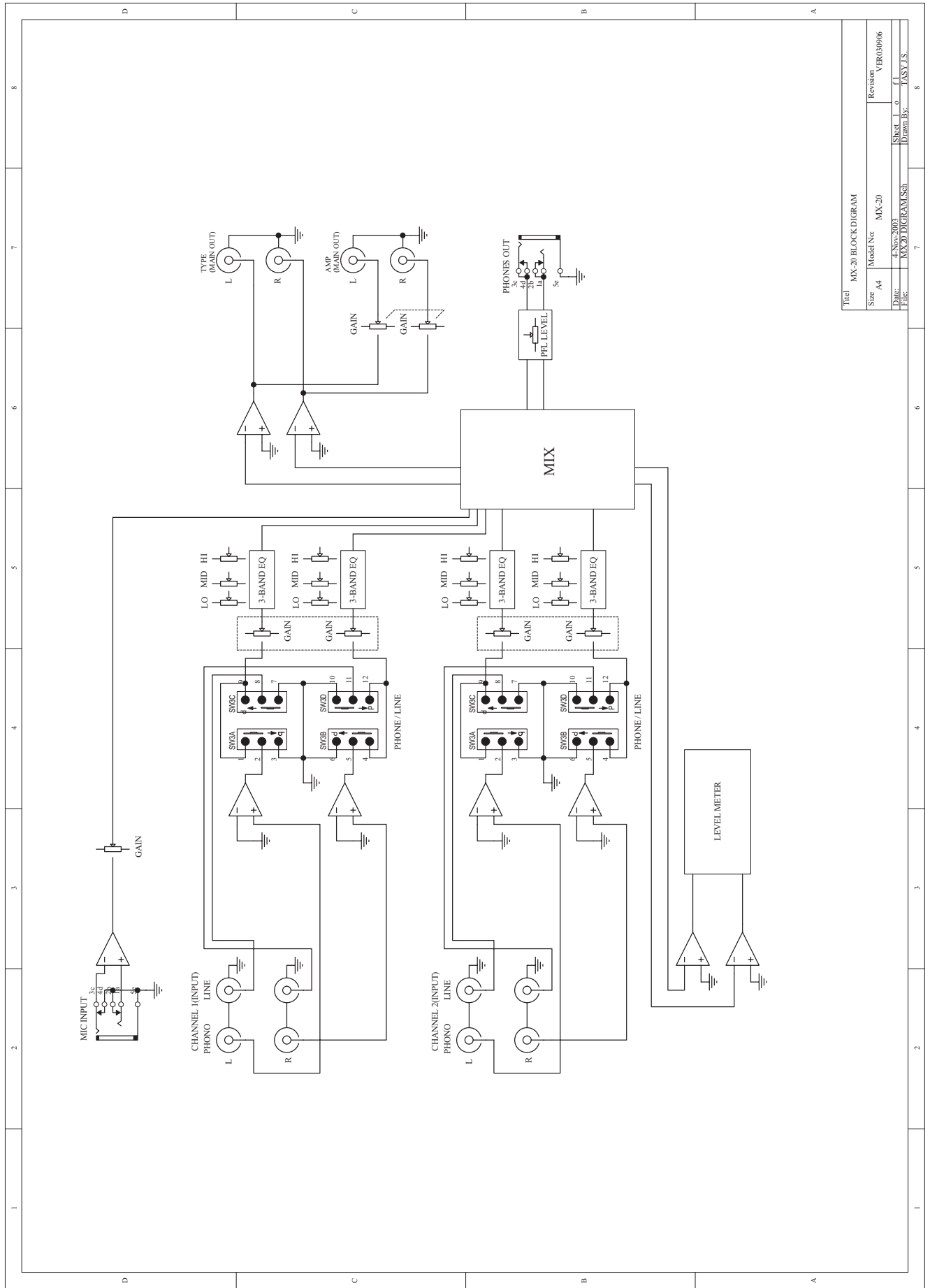

Title: MX-20 BLOCK DIAGRAM	
Size: A4	Model No: MX-20
Date: 4-Nov-2003	Revision: VER03/0906
File: MX20.DIGRAM.Sch	Sheet: 1 of 1
	Drawn By: TASTY J.S.

## 6. WARRANTY

### 1. WARRANTY REGISTRATION CARD

To obtain Warranty Service, the buyer should first fill out and return the enclosed Warranty Registration Card within 10 days of the Purchase Date.

All the information presented in this Warranty Registration Card gives the manufacturer a better understanding of the sales status, so as to purport a more effective and efficient after-sales warranty service.

Please fill out all the information carefully and genuinely, miswriting or absence of this card will void your warranty service.

### 2. RETURN NOTICE

2.1 In case of return for any warranty service, please make sure that the product is well packed in its original shipping carton, and it can protect your unit from any other extra damage.

2.2 Please provide a copy of your sales receipt or other proof of purchase with the returned machine, and give detail information about your return address and contact telephone number.

2.3 A brief description of the defect will be appreciated.

2.4 Please prepay all the costs involved in the return shipping, handling and insurance.

### 3. TERMS AND CONDITIONS

3.1 ▲LTO warrants that this product will be free from any defects in materials and/or workmanship for a period of 1 year from the purchase date if you have completed the Warranty Registration Card in time.

3.2 The warranty service is only available to the original consumer, who purchased this product directly from the retail dealer, and it can not be transferred.

3.3 During the warranty service, ▲LTO may repair or replace this product at its own option at no charge to you for parts or for labor in accordance with the right side of this limited warranty.

3.4 This warranty does not apply to the damages to this product that occurred as the following conditions:

- Instead of operating in accordance with the user's manual thoroughly, any abuse or misuse of this product.
- Normal tear and wear.
- The product has been altered or modified in any way.
- Damage which may have been caused either directly or indirectly by another product / force / etc
- Abnormal service or repairing by anyone other than the qualified personnel or technician.

And in such cases, all the expenses will be charged to the buyer.

3.5 In no event shall ▲LTO be liable for any incidental or consequential damages. Some states do not allow the exclusion or limitation of incidental or consequential damages, so the above exclusion or limitation may not apply to you.

3.6 This warranty gives you the specific rights, and these rights are compatible with the state laws, you may also have other statutory rights that may vary from state to state.

**SEIKAKU TECHNICAL GROUP LIMITED**  
**No. 1, Lane 17, Sec. 2, Han Shi W. Road, Taichung, 401 Taiwan**  
**<http://www.altomobile.com> Tel: 886-4-22313737**  
**email: [info@altomobile.com](mailto:info@altomobile.com) Fax: 886-4-22346757**

All rights reserved to ALTO Mobile. Due to continued development in response to customer feedback, product features, specifications and/or internal/external design may be changed without prior notice. No photocopying, translation or reproduction of any part of this user manual is allowed without prior written permission. Copyright © 2004 Seikaku Technical Group Limited.