

# User's Manual

# X34

3-WAY STEREO/ 4-WAY MONO  
ACTIVE CROSSOVER



[www.altoproaudio.com](http://www.altoproaudio.com)

Version 1.0 April 2002

— English —

## SAFETY RELATED SYMBOLS



This symbol, wherever it appears, alerts you to the presence of uninsulated dangerous voltage inside the enclosure-voltage that may be sufficient to constitute a risk of shock.



This symbol, wherever it appears, alerts you to important operating and maintenance instructions in the accompanying literature. Read the manual.



Protective grounding terminal.



Alternating current /voltage.



Hazardous live terminal.

**ON:** Denotes the apparatus turns on.

**OFF:** Denotes the apparatus turns off, because of using the single pole switch, be sure to unplug the AC power to prevent any electric shock before you proceed your service.

**WARNING:** Describes precautions that should be observed to prevent the danger of injury or death to the user.

**CAUTION:** Describes precautions that should be observed to prevent danger of the apparatus.

## WARNING

### • Power Supply

Ensure the source voltage matches the voltage of the power supply before turning ON the apparatus. Unplug this apparatus during lightning storms or when unused for long periods of time.

### • External Connection

The external wiring connected to the output hazardous live terminals requires installation by an instructed person, or the use of ready-made leads or cords.

### • Do not Remove any Cover

There are maybe some areas with high voltages inside, to reduce the risk of electric shock, do not remove any cover if the power supply is connected. The cover should be removed by the qualified personnel only.

No user serviceable parts inside.

### • Fuse

To prevent a fire, make sure to use fuses with specified standard (current, voltage, type). Do not use a different fuse or short circuit the fuse holder.

Before replacing the fuse, turn OFF the apparatus and disconnected the power source.

### • Protective Grounding

Make sure to connect the protective grounding to prevent any electric shock before turning ON the apparatus. Never cut off the internal or external protective grounding

wire or disconnect the wiring of protective grounding terminal.

### • Operating Conditions

This apparatus shall not be exposed to dripping or splashing and that no objects filled with liquids, such as vases, shall be placed on this apparatus. To reduce the risk of fire or electric shock, do not expose this apparatus to rain or moisture.

Do not use this apparatus near water.

Install in accordance with the manufacturer's instructions. Do not install near any heat sources such as radiators, heat registers, stoves, or other apparatus (including amplifiers) that produce heat. Do not block any ventilation openings.

No naked flame sources, such as lighted candles, should be placed on the apparatus.

## IMPORTANT SAFETY INSTRUCTIONS

- Read these instructions.
- Follow all instructions.
- Keep these instructions.
- Heed all warnings.
- Only use attachments/accessories specified by the manufacturer.

### • Power Cord and Plug

Do not defeat the safety purpose of the polarized or grounding type plug. A polarized plug has two blades with one wider than the other. A grounding type plug has two blades and a third grounding prong. The wide blade or the third prong are provided for your safety. If the provided plug does not fit into your outlet, consult an electrician for replacement of the obsolete outlet.

Protect the power cord from being walked on or pinched particularly at plugs, convenience receptacles, and the point where they exit from the apparatus.

### • Cleaning

When the apparatus needs a cleaning, you can blow off dust from the apparatus with a blower or clean with rag etc. Don't use solvents such as benzol, alcohol, or other fluids with very strong volatility and flammability for cleaning the apparatus body.

Clean only with dry cloth.

### • Servicing

Refer all servicing to qualified personnel. To reduce the risk of electric shock, do not perform any servicing other than that contained in the operating instructions unless you are qualified to do so.

Servicing is required when the apparatus has been damaged in any way, such as power supply cord or plug is damaged, liquid has been spilled or objects have fallen into the apparatus, the apparatus has been exposed to rain or moisture, does not operate normally, or has been dropped.

## Preface

Dear Customer:

Thanks for choosing ▲LTO Active Crossover and thanks for choosing the one of results of ▲LTO AUDIO TEAM job and researches.

For our ▲LTO AUDIO TEAM, music and sound are more than a job...are first of all passion and let us say...our obsession!

We have been designing professional audio products for a long time in cooperation with some of the major brands in the world in the audio field.

The ▲LTO line presents unparalleled analogue and digital products made by Musicians for Musicians in our R&D Centres in Italy, Netherlands, United Kingdom and Taiwan. The core of our digital audio products is a sophisticated DSP (Digital sound processor) and a large range of state of the art algorithms which have been developed by our Software Team for the last 7 years.

Because we are convinced you are the most important member of ▲LTO AUDIO TEAM and the one confirming the quality of our job, we'd like to share with you our work and our dreams, pay attention to your suggestions and your comments.

Following this idea we create our products and we will create the new ones! From our side, we guarantee you and we will guarantee you also in future the best quality, the best fruits of our continuous researches and the best prices.

Our ▲LTO Active Crossover is the result of many hours of listening and tests involving common people, area experts, musicians and technicians.

The results of this effort is an efficient and effective electronic crossover solution, which will give you precise control and superior sound from your loudspeaker system.

Nothing else to add, but that we would like to thank all the people that made the ▲LTO Active Crossover a reality available to our customers, and thank our designers and all the ▲LTO staff, there to make possible the realization of products containing our idea of music and sound and there to support you, our customers, in the best way, conscious that you are our best richness.

Thank you very much.

▲LTO AUDIO TEAM

## TABLE OF CONTENTS

<b>1. INTRODUCTION .....</b>	<b>4</b>
<b>2. FEATURE LIST .....</b>	<b>4</b>
<b>3. CONTROL ELEMENTS.....</b>	<b>4</b>
3.1 The Front Panel	
<b>a. Guidable Map for The Front Panel</b>	
<b>b. Supplementary Descriptions for The Front Panel</b>	
3.2 The Rear Panel	
<b>a. Guidable Map for The Rear Panel</b>	
<b>b. Supplementary Descriptions for The Rear Panel</b>	
<b>4. INSTALLATION &amp; CONNECTION .....</b>	<b>6</b>
4.1 Mains Connection	
4.2 Audio Connection	
4.3 Rack Mounting	
<b>5. APPLICATION.....</b>	<b>7</b>
5.1 X34 3-Way Stereo	
5.2 X34 4-Way Mono	
<b>6. TECHNICAL SPECIFICATIONS.....</b>	<b>9</b>
<b>7. WARRANTY .....</b>	<b>9</b>

# 1. INTRODUCTION

Thank you very much for expressing your confidence in ▲LTO products by purchasing our X34 Active Crossover. With the X34 you have acquired an extremely musical and flexible Active Crossover.

The ▲LTO X34 Active Crossover is a single rack unit, dual channels electronic crossover capable of managing the frequency control for stereo 3-way and mono 4-way speaker systems. The X34 Active Crossover is an ideal crossover solution for most small and large PA systems, live sound venues, commercial installations, recording studio monitors and DJ set-ups. In addition to its flexibility in configuring to different sound systems, the X34 Active Crossover has advanced features such as Clip LED Indicators, CD Horn Equalization, and individual Phase and Mute switches per frequency band.

The X34 Active Crossover is an effective and efficient electronic crossover solution, which will give you precise control and superior sound from your loudspeaker system.

# 2. FEATURE LIST

- Single rack unit ( 1U)
- Robust and Compact design
- Phase inversion switches
- Servo-balanced XLR inputs/outputs.
- State-variable Linkwitz / Riley 24dB/Octave filters
- Switchable constant directivity horn equalization circuit for use with horns requiring a high frequency boost
- Clip LED indicators
- Mute switches
- Designed for the most precise accurate control
- Top audio performances with high slew rate circuitry
- Over than 115dB dynamic range for transparent sound
- Manufactured Under ISO9001 Certified management system

# 3. CONTROL ELEMENTS

## 3.1 The Front Panel

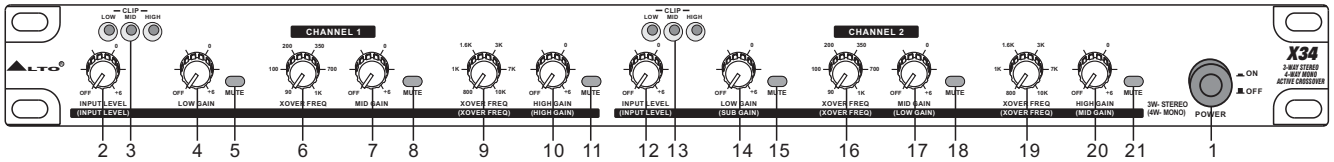

### a. Guidable Map for The Front Panel

X34 • 3-way stereo / 4-way mono active crossover		
	3-WAY STEREO MODE	4-WAY MONO MODE
1	Power Switch	
2	Ch1 Input Level	Input Level
3	Ch1 LOW,Ch1 MID&Ch1 HIGH Clip LEDs	HIGH Clip LED
4	Ch1 LOW Gain	(not used)
5	Ch1 LOW Mute	(not used)
6	Ch1 LOW-MID Crossover Frequency	(not used)
7	Ch1 MID Gain	(not used)
8	Ch1 MID Mute	(not used)
9	Ch1 MID-HIGH Crossover Frequency	MID-HIGH Crossover Frequency
10	Ch1 HIGH Gain	HIGH Gain
11	Ch1 HIGH Mute	HIGH Mute

12	Ch2 Input Level	(not used)
13	Ch2 LOW,Ch2 MID&Ch2 HIGH Clip LEDs	SUB, LOW & MID Clip LEDs
14	Ch2 LOW Gain	SUB Gain
15	Ch2 LOW Mute	SUB Mute
16	Ch2 LOW-MID Crossover Frequency	SUB-LOW Crossover Frequency
17	Ch2 MID Gain	LOW Gain
18	Ch2 MID Mute	LOW Mute
19	Ch2 MID-HIGH Crossover Frequency	LOW-MID Crossover Frequency
20	Ch2 HIGH Gain	MID Gain
21	Ch2 HIGH Mute	MID Mute

### b. Supplementary Descriptions for The Front Panel

- **Power switch(1)**  
Turn the apparatus ON/OFF.
- **Clip LED (3 for Ch1 and 13 for Ch2)**  
This LED will light when output capability is being exceeded with clipping distortion. Occasional flickering of the Clip LED is acceptable, but if it remains on continuously, you should turn down the level control or reduce the output level of the proceeding component to avoid audible distortion.
- **Mute switch (5,8,11 for Ch1 and 15,18,21 for Ch2)**  
These mute switches mute the input signal of each frequency range.

## 3.2 The Rear Panel

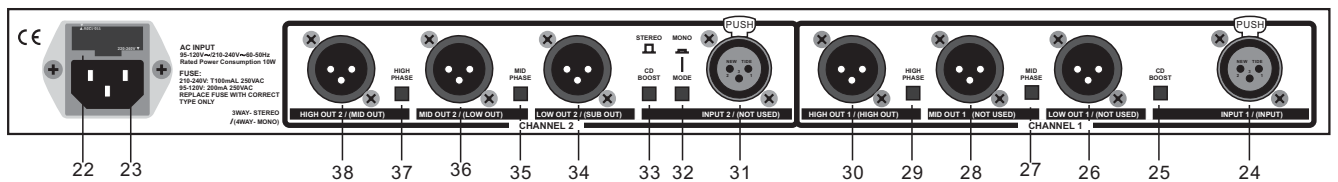

### a. Guidable Map for The Rear Panel

		X34 • 3-way stereo / 4-way mono active crossover	
		3-WAY STEREO MODE	4-WAY MONO MODE
22	Fuse Holder		
23	AC Inlet		
24	Ch1 Line Input	Line Input	
25	Ch1 Constant Directivity Boost	Constant Directivity Boost	
26	Ch1 LOW Output	(not used)	
27	Ch1 MID Phase Inversion	(not used)	
28	Ch1 MID Output	(not used)	
29	Ch1 HIGH Phase Inversion	(not used)	
30	Ch1 HIGH Output	HIGH Output	
31	Ch2 Line Input	(not used)	
32	Stereo / Mono Mode		
33	Ch2 Constant Directivity Boost	(not used)	
34	Ch2 LOW Output	SUB Output	
35	Ch2 MID Phase Inversion	LOW Phase Inversion	
36	Ch2 MID Output	LOW Output	
37	Ch2 HIGH Phase Inversion	MID Phase Inversion	
38	Ch2 HIGH Output	MID Output	

## b. Supplementary Descriptions for The Rear Panel

- **Fuse holder & AC inlet ( 22 & 23 )**

This is a dual voltage unit. Before you attempt to connect and operate the unit, please make sure that your local voltage matches the voltage on the fuse-holder cover.

**Caution:** The fuse protecting the AC supplies circuits of this unit. The fuse can only be changed by a qualified technician, in the event of a fault or changing the supply voltage. If the fuse continues to blow after replacing, discontinue use of this unit before repaired.

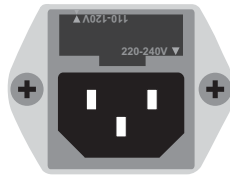

THIS IS SET FOR  
110V AC TO 120V  
AC OPERATION

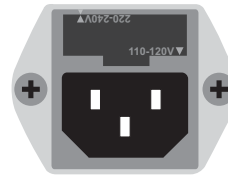

THIS IS SET FOR  
220V AC TO 240V  
AC OPERATION

The fuse-holder above the AC connector on the rear of the chassis has 3 triangular markers (please refer to the above pictures), with two of these triangles opposing each other, your unit is set to the operating Voltage printed next to these markers.

To change, pull fuse-holder out and rotate 180°, then push in again.

- **Inputs & Outputs ( 24 & 26, 28, 30 for Ch1 and 31 & 34, 36, 38 for Ch2 )**

All inputs and outputs are floating and balanced when connected to other floating and balanced equipment. Any combination of balanced and unbalanced operation is permitted. ( see also " Audio Connection " )

- **CD Boost ( 25 for Ch1 and 33 for Ch2 )**

The Constant Directivity horn equalization circuit is to be used with horns that require a high frequency boost, to smooth the high frequency response of the sound system. The provided boost is +3dB@3.5kHz rising 6dB per octave to 22.5kHz.

Consult your horn manufacturer to determine whether it is needed in your circumstance.

No changes need to be made to operate without the constant directivity boost.

If the constant directivity equalization circuit is desired on a particular channel then depress the corresponding switch labeled " CD BOOST " . There is one switch for each channel located near to the input socket. If two or more channels are ganged together, then use only the switch near to the used input socket. ( the switch near to the unused input socket has no effect on the circuit when ganged ).

- **Phase inversion (27, 29, for Ch1 and 35,37 for Ch2)**

These phase inversion switches reverse the audio signal's phase by 180°. Normally, you won't need this switch, however, in some cases, it might be necessary. For example, the inversion of the pins of the XLR connector may be necessary to alter the audio phase to compensate for phase cancellation.

- **Mode switch (32)**

This switch sets the operational mode of this unit. When it is pressed, this unit is in the state of mono application, you can operate it as a 4-way mono crossover (high/mid/ low/ sub).

Otherwise, this unit is in the state of stereo application, you can operate it as a 3- way stereo crossover (high/mid/low).

## 4. INSTALLATION & CONNECTION

### 4.1 Mains Connection

Please ensure that the ▲LTO X34 Active Crossover is set to the correct supply voltage before plugging the power cord into the wall outlet , use the same fuse as marked on the fuse holder at the AC power connection socket.

The mains connection of the ▲LTO X34 Active Crossover is made by using the enclosed mains cable and a standard IEC receptacle. It meets all of the international safety certification requirements.

### 4.2 Audio Connection

The ▲LTO X34 Active Crossover presents with balanced XLR connectors, and it can be interfaced by several ways to support a variety of applications without any signal loss.

**a. Wiring Configuration**

Either the 1/4" TRS (Tip-Ring-Sleeve) jack or the XLR servo connector can be wired in balanced and unbalanced modes. Please wire your systems as the following examples:

• For 1/4" TRS jack

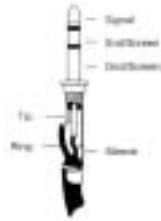

1/4" TRS jack  
Unbalanced Input

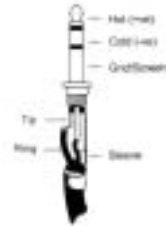

1/4" TRS jack  
Balanced Input

• For XLR connector

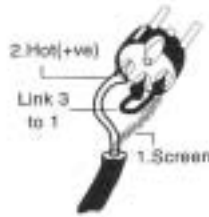

XLR Unbalanced Input

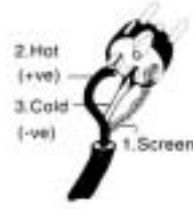

XLR Balanced Input

**b. In Line Connection**

For these applications, the X34 Active Crossover provides XLR connectors to easily interface with most professional audio devices. Follow the configuration examples below for your particular connection.

• **Balanced**

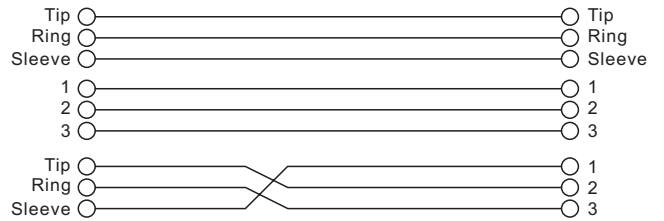
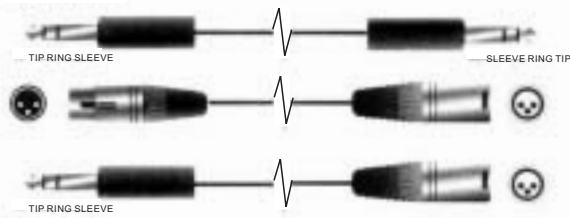

• **Unbalanced**

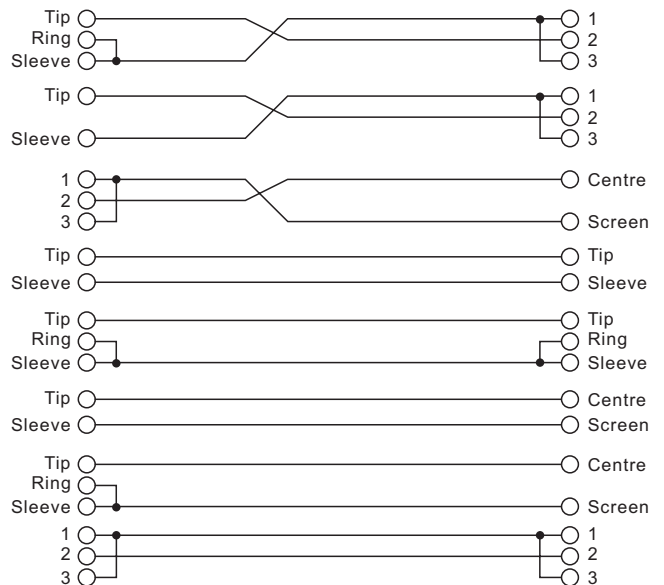
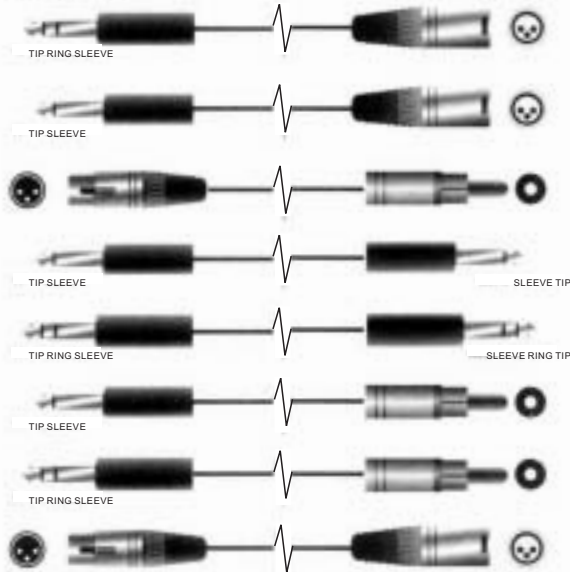

**4.3. Rack Mounting**

The most secure mounting is on a universal rack shelf available from various rack manufacturers or your music dealer. The X34 Active Crossover fits into one standard 19" rack unit of space. Please allow at least an additional 4" depth for the connectors on the rear panel. Be sure that there is enough air space around the unit for sufficient ventilation and please do not place the X34 Active Crossover on high temperature devices such as power amplifiers etc. to avoid overheating.



## 5. APPLICATION

### 5.1 X34 3-Way Stereo

If you want to present your X34 Active Crossover in a 3-way stereo application, please connect the unit in your system as the following illustration step by step:

1. Set Mode switch into stereo Mode.
2. Plug the Left line-in into INPUT 1 and the Right line-in into INPUT 2.
3. Connect the LOW OUT 1 to the Left input of the Low frequency amplifier, and the LOW OUT 2 to the Right input of the Low frequency amplifier.
4. Connect the MID OUT 1 to the Left input of the Mid frequency amplifier, and the MID OUT 2 to the Right input of the Mid frequency amplifier.
5. Connect the HIGH OUT 1 to the Left input of the High frequency amplifier, and the HIGH OUT 2 to the Right input of the High frequency amplifier.

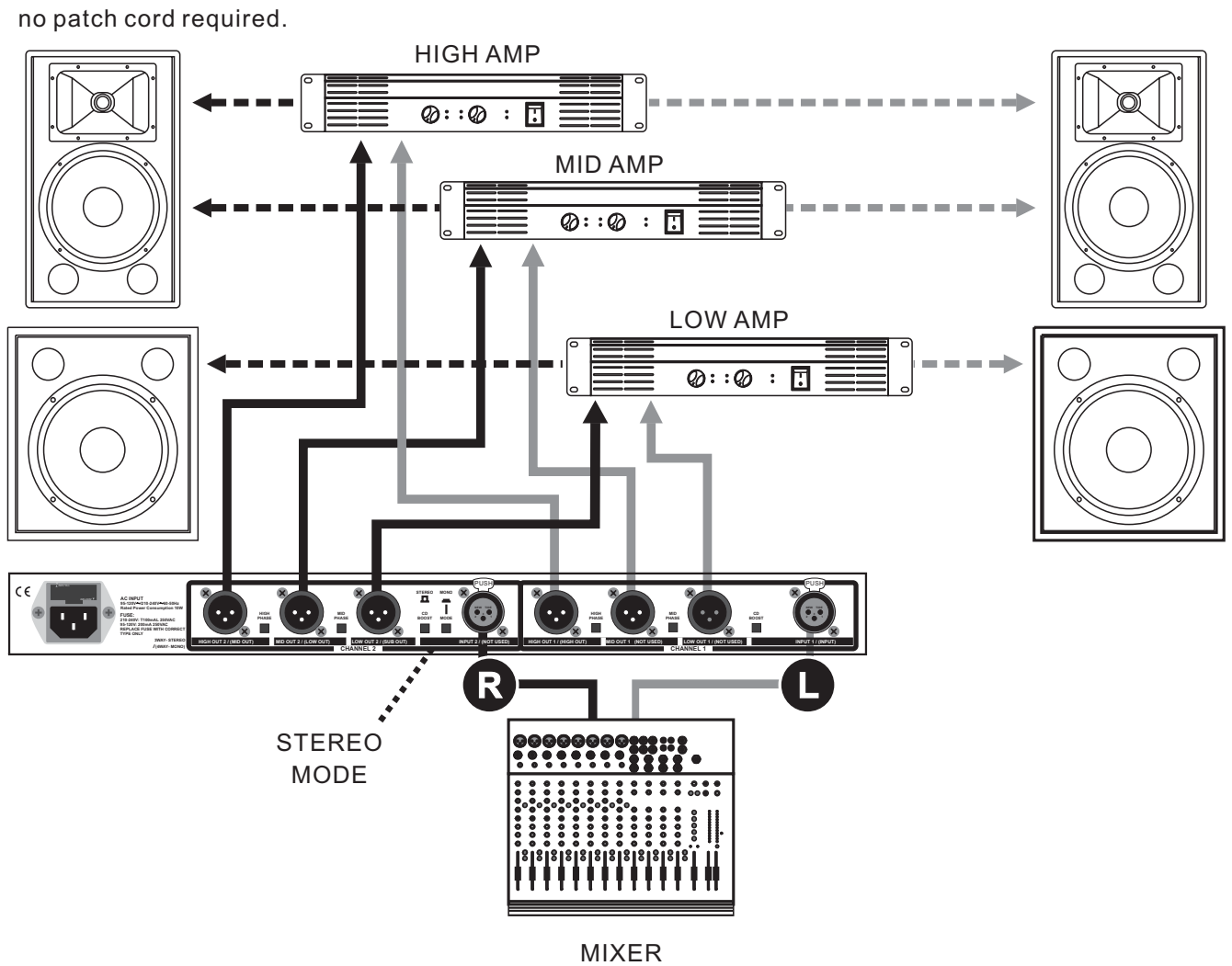

### 5.2 X34 4-Way Mono

Otherwise, if you want to present your X34 Active Crossover in a 4-way mono application, please connect the unit to your system as the following illustration step by step:

1. Set Mode switch to mono Mode.
2. Plug the line-in into INPUT 1.
3. Connect LOW OUT 2 to the Sub frequency amplifier.
4. Connect MID OUT 2 to the Low frequency amplifier.
5. Connect HIGH OUT 2 to the Mid-range frequency amplifier.
6. Connect HIGH OUT 1 to the High frequency amplifier.

no patch cord required

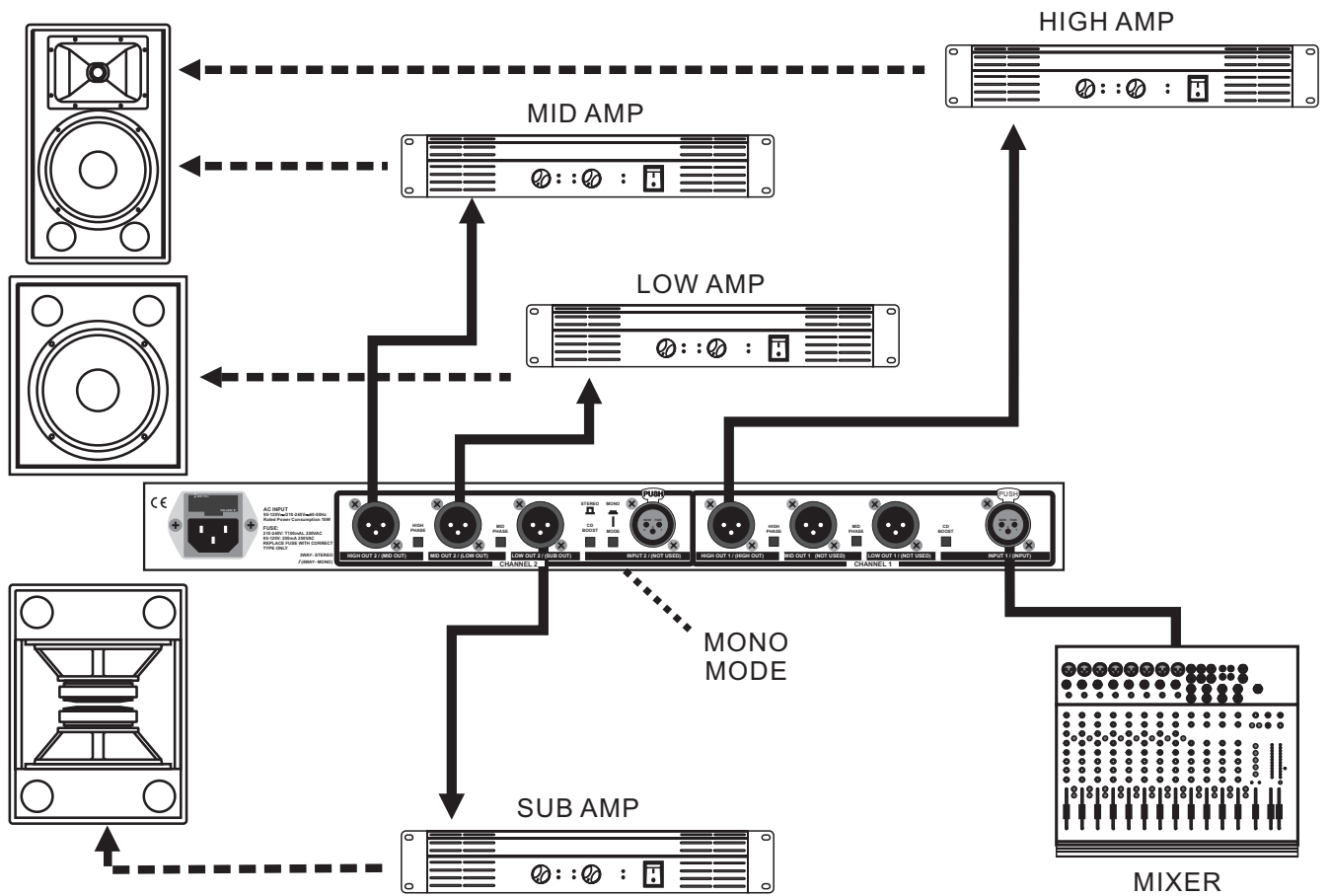

**NOTE:** Do not connect anything to INPUT 2.  
 Do not connect anything from LOW OUT 1 and from MID OUT 1  
 (These inputs/outputs are automatically normalised when unplugged).

The same time, please pay more attention to the front panel control, for it is really different from the 3-way stereo application .

**Front Panel**

- |                       |  |
|-----------------------|--|
| INPUT 1               | main input control                     |
| LOW Gain 1            | set to 0 and Mute                      |
| LOW-MID XOVER FREQ 1  | (not used)                             |
| MID Gain 1            | set to 0 and Mute                      |
| MID-HIGH XOVER FREQ 1 | MID-HIGH Crossover control             |
| HIGH Gain 1           | High frequency amplifier level control |
| INPUT 2               | set to 0                               |
| LOW Gain 2            | Sub frequency amplifier level control  |
| LOW-MID XOVER FREQ 2  | SUB-LOW Crossover control              |
| MID Gain 2            | Low frequency amplifier level control  |
| MID-HIGH XOVER FREQ 2 | LOW-MID Crossover control              |
| HIGH Gain 2           | Mid frequency amplifier level control  |

## 6. TECHNICAL SPECIFICATIONS

### Electrical

LOW-MID Frequency Range	90Hz-1KHz
MID-HIGH Frequency Range	800Hz-10KHz
HUM & Noise	Av=0db, fc=230Hz,2.3KHz
LOW Section (Output@0dB)	<98dBu
MID Section(Output@0dB)	<-95dBu
HIGH Section(Output @0dB)	<93dBu
S/N Ratio	114dB

### Controls

Input Level	continuously variable
Output Level	low, high continuously variable
CD Boost	rear panel switch
Mute	low, mid, high front panel switches
Phase	rear panel switch

### Power Supply

Connector type	3-pole IEC , grounded
Type	Servo controlled , stabilized
Mains supply	95-120V~/210-240V~,60-50Hz
Power Rating	10W

### Physical

Dimensions	483(W)×194.5(D)×44(H)mm (19"×7.7"×1.7")
Weight	2.5Kg(5.51lb)

## 7. WARRANTY

### 1. WARRANTY REGISTRATION CARD

To obtain Warranty Service, the buyer should first fill out and return the enclosed Warranty Registration Card within 10 days of the Purchase Date.

All the information presented in this Warranty Registration Card gives the manufacturer a better understanding of the sales status, so as to purport a more effective and efficient after-sales warranty service. Please fill out all the information carefully and genuinely, miswriting or absence of this card will void your warranty service.

### 2. RETURN NOTICE

- 2.1 In case of return for any warranty service, please make sure that the product is well packed in its original shipping carton, and it can protect your unit from any other extra damage.
- 2.2 Please provide a copy of your sales receipt or other proof of purchase with the returned machine ,and give detail information about your return address and contact telephone number .
- 2.3 A brief description of the defect will be appreciated.
- 2.4 Please prepay all the costs involved in the return shipping, handling and insurance.

### 3. TERMS AND CONDITIONS

- 3.1 ▲LTO warrants that this product will be free from any defects in materials and/or workmanship for a period of 1 year from the purchase date if you have completed the Warranty Registration Card in time.
- 3.2 The warranty service is only available to the original consumer, who purchased this product directly from the retail dealer, and it can not be transferred.
- 3.3 During the warranty service,▲LTO may repair or replace this product at its own option at no charge to you for parts or for labor in accordance with the right side of this limited warranty.
- 3.4 This warranty does not apply to the damages to this product that occurred as the following conditions:
  - Instead of operating in accordance with the user's manual thoroughly, any abuse or misuse of this product.
  - Normal tear and wear.
  - The product has been altered or modified in any way.
  - Damage which may have been caused either directly or indirectly by another product / force / etc
  - Abnormal service or repairing by anyone other than the qualified personnel or technician.And in such cases, all the expenses will be charged to the buyer.
- 3.5 In no event shall ▲LTO be liable for any incidental or consequential damages. Some states do not allow the exclusion or limitation of incidental or consequential damages, so the above exclusion or limitation may not apply to you.
- 3.6 This warranty gives you the specific rights, and these rights are compatible with the state laws, you may also have other statutory rights that may vary from state to state.