

evolutionwireless 

EM 100



Contents

Important safety instructions	2
The EM 100 G3 stationary receiver	4
The frequency bank system	4
Delivery includes	5
Product overview	6
Overview of the EM 100 receiver	6
Overview of the displays	7
Putting the receiver into operation	8
Preparing the receiver for use	8
Connecting an amplifier/mixing console	12
Connecting the mains unit	12
Using the receiver	12
Switching the receiver on/off	12
Synchronizing a transmitter with the receiver	13
Deactivating the lock mode temporarily	14
Muting the audio signal	14
Selecting a standard display	15
Using the operating menu	16
The buttons	16
Overview of the operating menu	16
Adjustment tips	18
Standard displays with additional functions	18
Synchronizing a transmitter with the receiver	19
Cleaning the receiver	21
If a problem occurs	21
Specifications	23
Manufacturer Declarations	25



For more detailed information on the individual sections of this instruction manual, visit the EM 100 G3 product page on our website at www.sennheiser.com.



There you can also view an animated instruction manual.

Important safety instructions

- Read this instruction manual.
- Keep this instruction manual. Always include this instruction manual when passing the device and the mains unit on to third parties.
- Heed all warnings and follow all instructions in this instruction manual.
- Only clean the device and the mains unit when they are not connected to the mains. Use a cloth for cleaning.
- Refer all servicing to qualified service personnel.
Servicing is required if the device or the mains unit have been damaged in any way, liquid has been spilled, objects have fallen inside, the device or the mains unit have been exposed to rain or moisture, do not operate properly or have been dropped.
- **WARNING:** To reduce the risk of fire or electric shock, do not use the device and the mains unit near water and do not expose them to rain or moisture. Do not place objects filled with liquids, such as vases or coffee cups, on the device.
- Only use the supplied mains unit.
- Unplug the mains unit from the wall socket
 - to completely disconnect the device from the mains,
 - during lightning storms or
 - when unused for long periods of time.
- Only operate the mains unit from the type of power source specified in the chapter “Specifications” (see page 23).
- Ensure that the mains unit is
 - in a safe operating condition and easily accessible,
 - properly plugged into the wall socket,
 - only operated within the permissible temperature range,
 - not covered or exposed to direct sunlight for longer periods of time in order to prevent heat accumulation (see “Specifications” on page 23).
- Do not block any ventilation openings. Install the device and the mains unit in accordance with the instructions given in this instruction manual.
- Do not install the device and the mains unit near any heat sources such as radiators, stoves, or other devices (including amplifiers) that produce heat.
- Only use attachments/accessories specified by Sennheiser.
- When replacement parts are required, only use replacement parts specified by Sennheiser or those having the same characteristics as the original part. Unauthorized substitutions may result in fire, electric shock, or other hazards.
- Do not overload wall outlets and extension cables as this may result in fire and electric shock.

- **Danger due to high volumes**

This device is capable of producing sound pressure exceeding 85 dB(A). 85 dB(A) is the sound pressure corresponding to the maximum permissible volume which is by law (in some countries) allowed to affect your hearing for the duration of a working day. It is used as a basis according to the specifications of industrial medicine. Higher volumes or longer durations can damage your hearing. At higher volumes, the duration must be shortened in order to prevent hearing damage. The following are sure signs that you have been subjected to excessive noise for too long a time:

- You can hear ringing or whistling sounds in your ears.
- You have the impression (even for a short time only) that you can no longer hear high notes.

Intended use

Intended use of the ew 100 G3 series devices includes:

- having read these instructions especially the chapter “Important safety instructions”,
- using the devices within the operating conditions and limitations described in this instruction manual.

“Improper use” means using the devices other than as described in these instructions, or under operating conditions which differ from those described herein.

The EM 100 G3 stationary receiver

The EM 100 G3 stationary receiver is part of the evolution wireless series generation 3 (ew G3). With this series, Sennheiser offers high-quality state-of-the-art RF transmission systems with a high level of operational reliability and ease of use. Transmitters and receivers permit wireless transmission with studio-quality sound.

Features of the evolution wireless 100 G3 series:

- Optimized PLL synthesizer and microprocessor technology
- HDX noise reduction system
- Pilot tone squelch control
- True diversity technology
- Switching bandwidth of 42 MHz
- Scan function (Easy Setup) for scanning the frequency banks for unused channels

The frequency bank system

Please note: Frequency usage is different for each country. Your Sennheiser partner will have all the necessary details on the available legal frequencies for your area.

The receiver is available in 6 UHF frequency ranges with 1,680 receiving frequencies per frequency range:

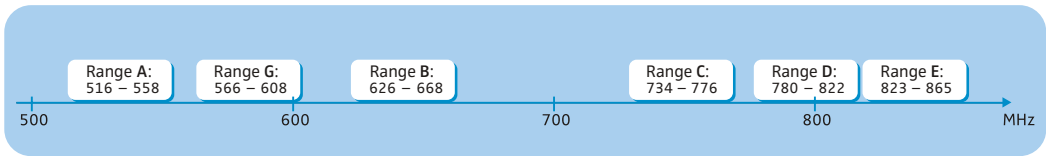

Each frequency range (A–E, G) offers 21 frequency banks with up to 12 channels each:

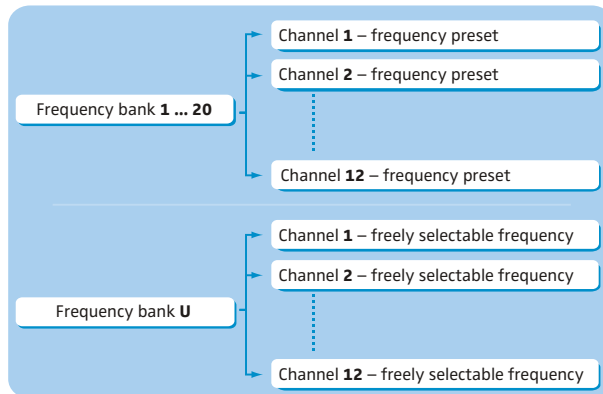

Each of the channels in the frequency banks “1” to “20” has been factory-preset to a fixed receiving frequency (frequency preset).

The factory-preset frequencies within one frequency bank are intermodulation-free. These frequencies cannot be changed.

For an overview of the frequency presets, please refer to the supplied frequency information sheet. Updated versions of the frequency information sheet can be downloaded from the EM 100 G3 product page on our website at www.sennheiser.com.

The frequency bank "U" allows you to freely select and store receiving frequencies. It might be that these receiving frequencies are **not** intermodulation-free (see page 20).

Delivery includes

The packaging contains the following items:

- 1 EM 100 G3 stationary receiver
- 1 mains unit
- 2 rod antennas
- 2 stacking elements
- 1 instruction manual
- 1 frequency information sheet
- 1 RF licensing information sheet
- 4 device feet

Product overview

Overview of the EM 100 receiver

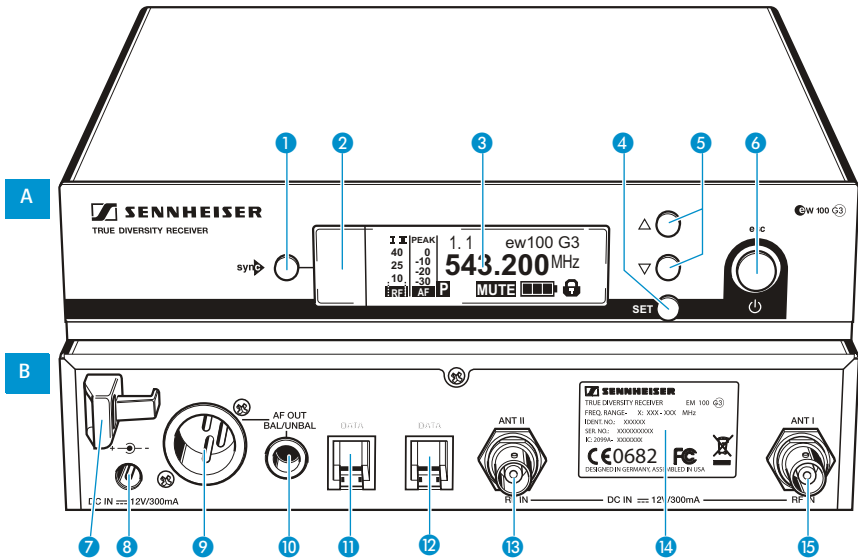

A Operating elements – front panel

- 1 **sync** button
- 2 Infra-red interface
- 3 Display panel, backlit in orange
- 4 **SET** button
- 5 **UP/DOWN** button
- 6 **STANDBY** button, serves as the ESC (cancel) key in the operating menu

B Operating elements – rear panel

- 7 Cable grip for power supply DC cable
- 8 DC socket (**DC IN**) for connection of mains unit
- 9 Audio output (**AF OUT BAL**), XLR-3M socket, balanced
- 10 Audio output (**AF OUT UNBAL**), ¼" (6.3 mm) jack socket, unbalanced
- 11 Service interface (**DATA**)
- 12 Service interface (**DATA**)
- 13 Antenna input II (**ANT II**) with remote power supply input, BNC socket
- 14 Type plate
- 15 Antenna input I (**ANT I**) with remote power supply input, BNC socket

Overview of the displays

After switch-on, the receiver displays the standard display “Receiver Parameters”. For further illustrations and examples of the different standard displays, please refer to page 15. This standard display displays the operating states of the receiver.

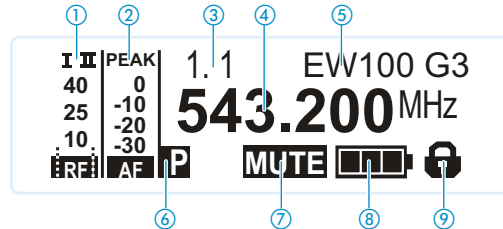

Display	Meaning
① RF level “RF” (Radio Frequency)	<p>Diversity display:</p> <p>I II Antenna input I is active I II Antenna input II is active</p> <p>RF signal level: RF Field strength of the transmitted signal RF Squelch threshold level</p>
② Audio level “AF” (Audio Frequency)	<p>Modulation of the transmitter with peak hold function</p> <p>When the level display for audio level shows full deflection, the audio input level is excessively high. When the transmitter is overmodulated frequently or for extended periods of time, the “PEAK” display is shown inverted.</p>
③ Frequency bank and channel	Current frequency bank and channel number
④ Frequency	Current receiving frequency
⑤ Name	Freely selectable name of the receiver
⑥ Pilot tone “P”	Activated pilot tone evaluation
⑦ Muting function “MUTE” (see page 14)	Receiver is muted Receiver does not output an audio signal (see also page 21).
⑧ Battery status of the transmitter	<p>Charge status:</p> <p> approx. 100% approx. 70% approx. 30%</p> <p> icon is flashing; charge status is critical</p>
⑨ Lock mode icon	Lock mode is activated

Putting the receiver into operation

Preparing the receiver for use

Setting up the receiver on a flat surface

Place the receiver on a flat, horizontal surface. Please note that the device feet can leave stains on delicate surfaces.



The stacking elements are designed to help protect the operating elements from damage or deformation, e.g. if the receiver is dropped. Therefore, fasten the stacking elements, even if you do not want to stack your receivers.

Fastening the stacking elements

To fasten the stacking elements 16:

- ▶ Unscrew and remove the two recessed head screws (M4x8) on each side of the receiver (see diagram).
- ▶ Secure the stacking elements 16 to the sides of the receiver using the previously removed recessed head screws (see diagram).

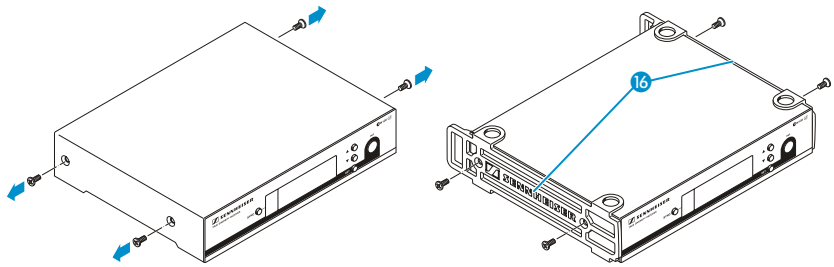

Fitting the device feet

The device feet are fitted to the base of the receiver (see diagram).



If you want to stack receivers (see following section), only fit the device feet to the base of the lowermost receiver.

Do not fit the device feet when mounting the receiver into a 19" rack.

- ▶ Clean the base of the receiver where you want to fix the device feet.
- ▶ Fix the device feet to the base of the receiver by peeling off the backing paper and fitting them as shown on the left.

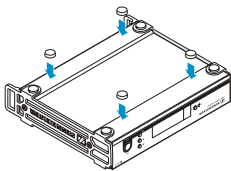

- Stacking receivers** ► Stack several receivers on top of each other.

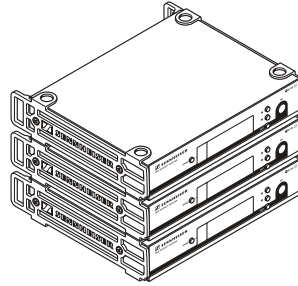

CAUTION!



Danger of injury due to toppling receiver stacks!

High receiver stacks can easily topple over.

- Place the stack on an absolutely flat surface.
- Secure the stack against toppling over.
- Fasten the stacking elements as described in the previous section.
- Stack the receivers so that the recesses of the stacking elements completely engage with each other.

Connecting the rod antennas

The supplied rod antennas 17 are suitable for use in good reception conditions.

- Connect the rod antennas 17 (see diagram).
- Align the antennas in a V-shape.

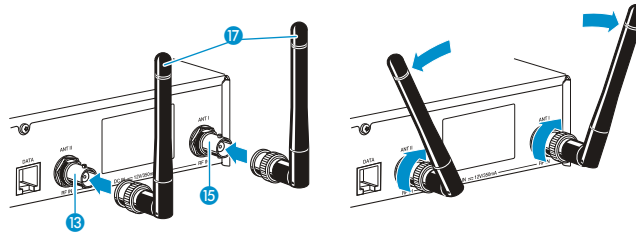

When using more than one receiver, we recommend connecting remote antennas and, if necessary, using Sennheiser antenna accessories. For more information, visit the ew G3 product page at www.sennheiser.com.

Mounting the receiver into a 19" rack



Do not mount the stacking elements and do not fit the rubber feet when rack mounting the receiver.

CAUTION!



Risks when rack mounting the receiver!

When installing the device in a closed or multi-rack assembly, please consider that, during operation, the ambient temperature, the mechanical loading and the electrical potentials will be different from those of devices which are not mounted into a rack.

- ▶ Make sure that the ambient temperature within the rack does not exceed the permissible temperature limit specified in the EM 100 G3 specifications.
- ▶ Ensure sufficient ventilation; if necessary, provide additional ventilation.
- ▶ Make sure that the mechanical loading of the rack is even.
- ▶ When connecting to the power supply, observe the information indicated on the type plate. Avoid circuit overloading. If necessary, provide overcurrent protection.
- ▶ When rack mounting, please note that intrinsically harmless leakage currents of the individual mains units may accumulate, thereby exceeding the allowable limit value. As a remedy, ground the rack via an additional ground connection.

Rack mounting one receiver

To mount the receiver into a rack, you require the GA 3 rack adapter (optional accessory):

- ▶ Secure the rack mount "ears" 20 (supplied with the GA 3 rack adapter) to the receiver in the same way as described for the stacking elements (see page 8).
- ▶ Secure the blanking plate 21 to one of the rack mount "ears" 20 using two recessed head screws (M 6x10) (see left-hand diagram).

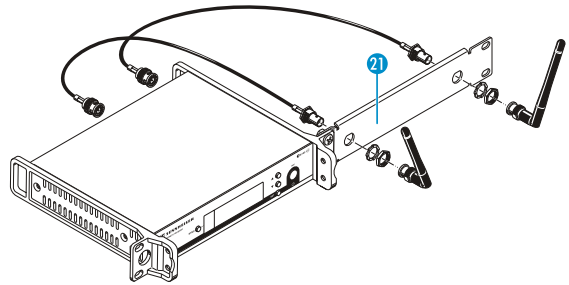
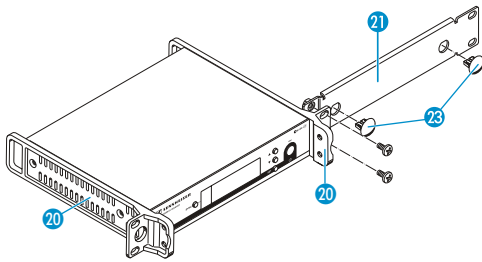

- ▶ Connect the antennas. There are two ways to connect the antennas:
 - You can connect the rod antennas 17 to the rear of the receiver (see page 9). In this case, insert the two blanking plugs 23 into the holes of the blanking plate (see left-hand diagram).
 - You can use the AM 2 antenna front mount kit (optional accessory) and mount the rod antennas to the front of the receiver (see right-hand diagram).



When using more than one receiver, we recommend connecting remote antennas and, if necessary, using Sennheiser antenna accessories. For more information, visit the ew G3 product page at www.sennheiser.com.

- ▶ Slide the receiver with the mounted blanking plate 21 into the 19" rack.
- ▶ Secure the rack mount "ears" 20 and the blanking plate 21 to the 19" rack.

- ▶ Align the antennas in a V-shape.

Rack mounting two receivers



When rack mounting two receivers side by side, you can only front mount the antennas when using the ASA 1 antenna splitter in conjunction with the AM 2 antenna front mount kit and an additional GA 3 rack adapter. For more information, visit ew G3 product pages at www.sennheiser.com.

We recommend using remote antennas.

To mount two receivers into a rack using the GA 3 rack adapter (optional accessory):

- ▶ Place the two receivers side by side upside-down onto a flat surface:

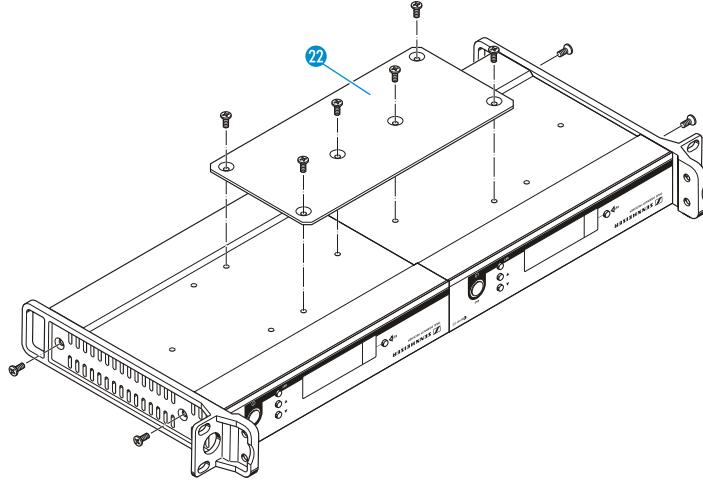

- ▶ Secure the jointing plate 22 to the receivers using six recessed head screws (M 3x6).

The rack mount "ears" are mounted instead of the stacking elements:

- ▶ Secure the rack mount "ears" to the receivers as described on page 8.

To mount the antennas:

- ▶ Use remote antennas, if necessary in conjunction with the ASA 1 antenna splitter. For more information, visit ew G3 product pages at www.sennheiser.com.

To mount the receivers into the 19" rack:

- ▶ Slide the receivers into the 19" rack.
- ▶ Secure the rack mount "ears" to the 19" rack.

Connecting an amplifier/mixing console

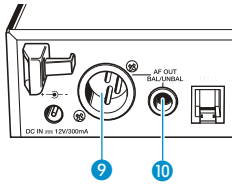

The receiver's XLR-3M socket 9 and the 1/4" (6.3 mm) jack socket 10 are connected in parallel.

- ▶ Use a suitable cable to connect the amplifier and/or the mixing console to the XLR-3M socket 9 or the 1/4" (6.3 mm) jack socket 10 (see also page 25).
- ▶ Via the operating menu, adjust the audio output level (AF OUT) of the receiver to the input of the amplifier or mixing console (see page 17). The audio output level is adjusted via the operating menu and is common for both sockets.

Connecting the mains unit

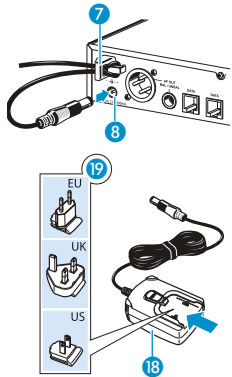

Only use the supplied mains unit. It is designed for the receiver and ensures safe operation.

- ▶ Insert the connector of the mains unit 18 into the socket 8 of the receiver.
- ▶ Pass the cable of the mains unit through the cable grip 7.
- ▶ Slide the supplied country adapter 19 onto the mains unit 18.
- ▶ Plug the mains unit 18 into a wall socket.

Using the receiver

To establish a transmission link, proceed as follows:

1. Switch the receiver on (see below).
2. Switch the transmitter on (see the instruction manual of the transmitter).
The transmission link is established and the receiver's RF level display "RF" reacts.



It is vital to observe the notes on frequency selection on page 19.

If you cannot establish a transmission link between transmitter and receiver:

- ▶ Make sure that transmitter and receiver are set to the same frequency bank and to the same channel.
- ▶ If necessary, read the chapter "If a problem occurs ..." on page 21.

Switching the receiver on/off

To switch the receiver on:



- ▶ Briefly press the **STANDBY** button 6.
The receiver switches on and the "Receiver Parameters" standard display appears.

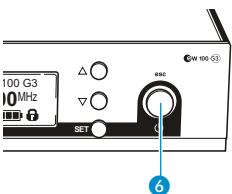

To switch the receiver to **standby mode**:

- ▶ If necessary, deactivate the lock mode (see page 14).



- ▶ Keep the **STANDBY** button **6** pressed until "OFF" appears on the display panel. The display panel then turns off.



When in the operating menu, pressing the **STANDBY** button **6** will cancel your entry (ESC function) and return you to the current standard display.

To completely switch the receiver **off**:

- ▶ Disconnect the receiver from the mains by unplugging the mains unit from the wall socket.

Synchronizing a transmitter with the receiver

You can synchronize a suitable transmitter of the ew 100 G3 series with the receiver. During synchronization, the following parameters are transferred to the transmitter:

Setting	Transferred parameters
"Frequency Preset"	Currently set frequency
"Name"	Freely selectable name currently set on the receiver
"Pilot Tone"	Current pilot tone setting of the receiver ("Inactive"/"Active")

To transfer the parameters:

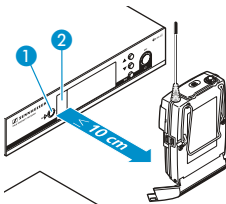

- ▶ Switch the transmitter and the receiver on.
- ▶ Press the **sync** button **1** on the receiver. "Sync" appears on the display panel of the receiver.
- ▶ Place the infra-red interface of the transmitter (see the instruction manual of the transmitter) in front of the infra-red interface of the receiver **2**. The parameters are transferred to the transmitter. When the transfer is completed, "✓" appears on the display panel. The receiver then switches back to the current standard display.

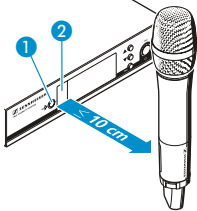

To cancel the transfer:

- ▶ Press the **STANDBY** button **6** on the receiver. "X" appears on the display panel of the receiver. "X" also appears if:
 - no transmitter was found or the transmitter is not compatible,
 - no transmitter was found and the synchronization process was canceled after 30 seconds,
 - you canceled the transfer.

Deactivating the lock mode temporarily

You can activate or deactivate the automatic lock mode via the "Auto Lock" menu item. If the lock mode is activated, you have to temporarily deactivate it in order to be able to operate the receiver:

- ▶ Press the **SET** button.
"Locked" appears on the display panel.
- ▶ Press the **UP/DOWN** button.
"Unlock?" appears on the display panel.

- ▶ Press the **SET** button.
The lock mode is temporarily deactivated:

When you are in the operating menu

The lock mode is deactivated as long as you are in the operating menu.

When one of the standard displays is shown

The lock mode is automatically activated after 10 seconds.

The lock mode icon  flashes prior to the lock mode being activated again.

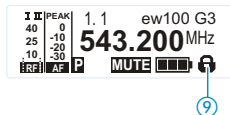

Muting the audio signal

To **mute** the audio signal:

- ▶ When one of the standard displays is shown on the display panel, press the **STANDBY** button.
"RX Mute On?" appears on the display panel.

- ▶ Press the **SET** button.
The audio signal is muted.

To **unmute** the audio signal:

- ▶ Press the **STANDBY** button.
"RX Mute Off?" appears on the display panel.

- ▶ Press the **SET** button.
The muting is canceled.

Selecting a standard display

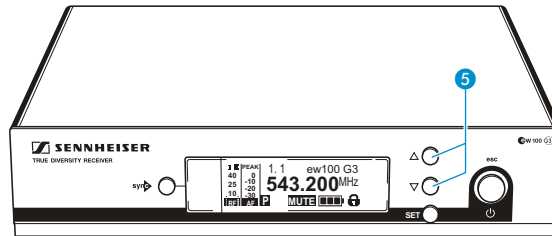



- ▶ Press the **UP/DOWN** button **5** to select a standard display.

Contents of the display	Selectable standard display
	"Receiver Parameters" appears after switch-on of the receiver and displays the receiver parameters (see page 7)
	"Soundcheck" (display with additional function) displays the signal quality within the transmission area (see page 18)
	"Guitar Tuner" * (display with additional function) displays the guitar tuner (see page 18)

* The **"Guitar Tuner"** standard display is deactivated upon delivery. To show this standard display, you have to activate it (see page 18).

Using the operating menu

The buttons

Button	Function of the button
Press the STANDBY button 	<ul style="list-style-type: none"> Switches the receiver on and off Cancels the entry and returns to the current standard display (ESC function) Mutes the receiver (special function, see page 14)
Press the SET button 	<ul style="list-style-type: none"> Changes from the current standard display to the operating menu Calls up a menu item Enters a submenu Stores the settings and returns to the operating menu
Press the UP/DOWN button 	<ul style="list-style-type: none"> Selects a standard display Changes to the next/previous menu item Changes the setting of a menu item





Overview of the operating menu

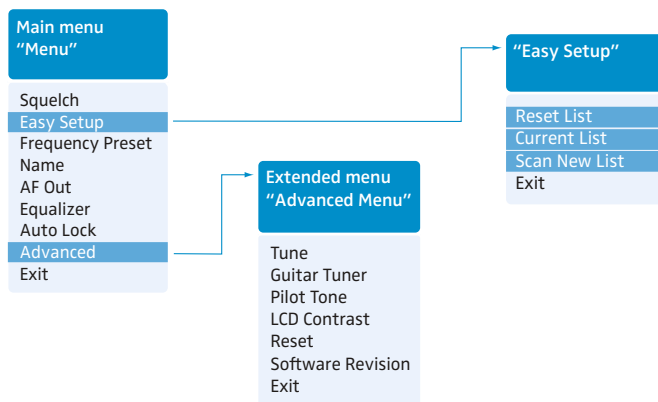

For more detailed information on the operating menu, refer to the instruction manual of the EM 100. This instruction manual can be downloaded from the EM 100 product page at www.sennheiser.com.



When one of the standard displays is shown on the display panel, you can get into the main menu by pressing **SET** button . The extended menu **"Advanced Menu"** and the submenu **"Easy Setup"** can be accessed via the corresponding menu items.

Display	Function of the menu item
Main menu "Menu"	
Squelch	<p>Adjusts the squelch threshold Adjustment range: 5 dBμV ("Low"), 15 dBμV ("Middle"), 25 dBμV ("High"), can be switched off Special function (for servicing purposes only): With the squelch threshold set to "Low", you switch the squelch off by keeping the DOWN  pressed for 3 seconds. If you then press the UP button , you switch the squelch on again.</p> <hr/> <p>CAUTION! Danger of hearing damage and material damage!</p> <p> If you switch the squelch off or adjust the squelch threshold to a very low value, loud hissing noise can occur in the receiver.</p> <p>The hissing noise can be loud enough to cause hearing damage or overload the loudspeakers of your system!</p> <ul style="list-style-type: none"> ▶ Always make sure that the squelch is switched on (see above). ▶ Before adjusting the squelch threshold, set the volume of the audio output level to the minimum. ▶ Never change the squelch threshold during a live transmission. <hr/>
Easy Setup	Scans for unused frequency presets, releases and selects frequency presets
Frequency Preset	Changes the frequency bank and the channel
Name	Enters a freely selectable name
AF Out	<p>Adjusts the audio output level Adjustment range: -24 dB to +24 dB, adjustable in 3-dB steps, 6 dB gain reserve Special function "gain reserve":</p> <ul style="list-style-type: none"> ▶ When you have adjusted a level of +18 dB, press the UP button  until the next higher value appears.
Equalizer	Changes the frequency response of the output signal
AutoLock	Activates/deactivates the automatic lock mode
Advanced	Calls up the extended menu "Advanced Menu"
Exit	Exits the operating menu and returns to the current standard display
Submenu "Easy Setup"	
Reset List	Releases all locked frequency presets and selects an unused frequency preset
Current List	Selects an unused frequency preset
Scan New List	Scans for unused receiving frequencies (frequency preset scan)
Exit	Exits the submenu "Easy Setup" and returns to the main menu

Display	Function of the menu item
Extended menu "Advanced Menu"	
Tune	Sets the receiving frequencies for the frequency bank "U" Special function: Sets a channel and a receiving frequency for the frequency bank "U": ▶ Select this menu item and call it up by pressing the SET button 4 until the channel selection appears.
Guitar Tuner	Selects the mode of the guitar tuner function
Pilot Tone	Activates/deactivates the pilot tone evaluation
LCD Contrast	Adjusts the contrast of the display panel
Reset	Resets the receiver
Software Revision	Displays the current software revision
Exit	Exits the extended menu "Advanced Menu" and returns to the main menu

Adjustment tips

The operating menu allows you to make settings for your receiver and your transmitters. The standard displays "Guitar Tuner" and "Soundcheck" can be called up by pressing the UP/DOWN, without having to get into the operating menu.

Standard displays with additional functions

Tuning a guitar (for SK transmitters only)

- ▶ Activate the "Guitar Tuner" standard display via the operating menu.
- ▶ Connect a guitar to your SK transmitter.
- ▶ Change to the "Guitar Tuner" standard display (see page 15).

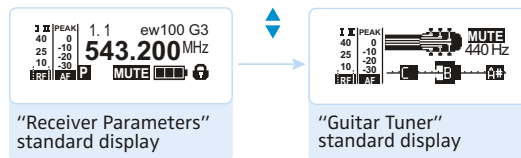

- ▶ Tune your guitar.
The receiver automatically recognizes the pitch of the plucked string.

Doing a soundcheck

By doing a soundcheck, you can check the reception area for field strength gaps ("dropouts") which cannot be compensated for by the receiver's diversity circuitry. You can do the soundcheck without the help of another person.

- ▶ Switch the transmitter on.
- ▶ On the receiver, change to the "Soundcheck" standard display.

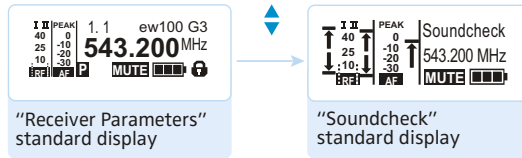

If no transmitter is being received or if the signal is below the squelch threshold level, "MUTE" appears.

- ▶ With the transmitter, walk up and down the transmission area. The receiver records the following parameters and displays them on the "Soundcheck" standard display:

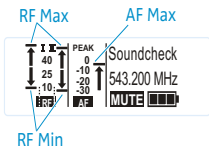

Display	Meaning	What to do ...
RF Min	Min. RF signal level: <ul style="list-style-type: none"> • must be well above the squelch threshold level for one of the two antennas 	<ul style="list-style-type: none"> ▶ Check if the antennas and the antenna cables are correctly connected. ▶ Improve the position of the antennas. ▶ If necessary, use antenna boosters.
RF Max	Max. RF signal level: <ul style="list-style-type: none"> • both antennas should reach 40 dBµV 	
AF Max	Max. audio level	<ul style="list-style-type: none"> ▶ On your transmitter, adjust the audio level as high as possible without the level display for audio level showing full deflection (AF Max is at a level with the PEAK display). For more information, refer to the instruction manual of the transmitter.

Synchronizing a transmitter with the receiver

When synchronizing a transmitter with a receiver, please observe the following:

- ▶ Only use a transmitter and a receiver from the same frequency range (see the type plate on the transmitter and the receiver).
- ▶ Make sure that the desired frequencies are listed in the enclosed frequency information sheet.
- ▶ Make sure that the desired frequencies are approved and legal in your country and, if necessary, apply for an operating license.

Synchronizing a transmitter with the receiver – individual operation

Upon delivery, transmitter and receiver are synchronized with each other. However, if you cannot establish a transmission link between transmitter and receiver, you have to synchronize the channels of the devices:

- ▶ With the receiver, perform a frequency preset scan to scan the frequency banks for unused channels ("Scan New List", see page 17).
- ▶ Select a channel on your receiver ("Current List", see page 17). The receiving frequency of the channel must be approved and legal in your country (see above).

- ▶ Synchronize a transmitter with the receiver via the infra-red interface (see page 13). This establishes a transmission link between the transmitter and the receiver.

Alternatively, you can set the channel on the transmitter manually:

- ▶ Make sure that you set the transmitter to the same frequency bank and the same channel as the receiver.
For information on the setting options of the transmitter, refer to the instruction manual of the transmitter.

Synchronizing transmitters with receivers – multi-channel operation

- ▶ Switch off all transmitters of your system that are to be automatically configured. Channels used by switched-on transmitters are displayed as “used”.
- ▶ With one of the receivers, perform a frequency preset scan to scan the frequency banks for unused channels (“Scan New List”, see page 17).
- ▶ Select a channel on this receiver (“Current List”, see page 17).
The receiving frequency of the channel must be approved and legal in your country (see above).
- ▶ Synchronize a transmitter with the receiver via the infra-red interface (see page 13). This establishes a transmission link between the transmitter and the receiver.
- ▶ Repeat for the remaining transmitter and receiver pairs as described above.

Your multi-channel system is now set up.

Alternatively, you can set the channel on the transmitter manually:

- ▶ Make sure that you set the transmitter to the same frequency bank and the same channel as the receiver.
For information on the setting options of the transmitter, refer to the instruction manual of the transmitter.

You can also freely select the receiving frequencies and store these frequencies in the frequency bank “U”.



If you are using the frequency bank “U”, it might be that the receiving frequencies are not intermodulation-free:

- ▶ For possible frequency combinations, please refer to the frequency information sheet or calculate the frequencies (see below).
-

If you want to use the frequency bank “U”:

- ▶ Make sure to use receivers of the same frequency range (see page 4 and the type plate of the receiver).
 - ▶ Only use frequencies that are approved and legal in your country (see page 19).
-



To ensure that the desired frequencies are intermodulation-free, proceed as follows:

- ▶ Calculate intermodulation-free frequencies using the “Sennheiser Intermodulation and Frequency Management (SIFM)” software (see www.sennheiser.com).
- ▶ Set each receiver to the same frequency bank.
- ▶ On one of the receivers, select a channel within this frequency bank (see page 18).
- ▶ Assign this channel one of the calculated receiving frequencies (see page 18).

- ▶ Synchronize a transmitter with the receiver (see page 13)
OR
- ▶ Manually set the transmitter to the same frequency bank, channel and frequency that you set on the receiver.
- ▶ Repeat for the remaining transmitters and receivers as described above.

Cleaning the receiver

CAUTION!



Liquids can damage the electronics of the receiver!

Liquids entering the housing of the device can cause a short-circuit and damage the electronics.

- ▶ Keep all liquids away from the receiver.
-
- ▶ Before cleaning, disconnect the device from the mains.
 - ▶ Use a slightly damp cloth to clean the receiver from time to time. Do not use any solvents or cleansing agents.

If a problem occurs ...

Problem	Possible cause	Possible solution
Receiver cannot be operated, "Locked" appears on the display panel	Lock mode is activated	Deactivate the lock mode (see page 14).
No RF signal	Transmitter and receiver are not on the same channel	Set the transmitter and receiver to the same channel. To do so, use the synchronization function (see page 13).
	Transmitter is out of range	Check the squelch threshold setting. Reduce the distance between transmitter and receiving antennas.
RF signal available, no audio signal, "MUTE" appears on the display panel	Transmitter is muted ("MUTE") or doesn't transmit a pilot tone	Cancel the muting (see the instruction manual of the transmitter or see page 13).
		Switch the pilot tone transmission on the transmitter on. Switch the pilot tone evaluation on the receiver off.
Audio signal has a high level of background noise	Receiver's squelch threshold is adjusted too high	Reduce the squelch threshold.
		Reposition the antennas
Audio signal has a high level of background noise	Transmitter sensitivity is adjusted too low/high	Adjust the transmitter sensitivity correctly.

If a problem occurs ...

Problem	Possible cause	Possible solution
Audio signal is distorted	Transmitter sensitivity is adjusted too high	Adjust the transmitter sensitivity correctly.
	Receiver's audio output level is adjusted too high	Reduce the audio output level ("AF Out", see page 17).
No access to a certain channel	During scanning, an RF signal has been detected on this channel and the channel has been locked	Set the transmitter operating on this channel to a different channel and redo the frequency preset scan.
	During scanning, a transmitter of your system operating on this channel has not been switched off	Switch the transmitter off and redo the frequency preset scan.
None of the diversity displays I or II appears on the display panel	Receiver's squelch threshold is adjusted too high	Reduce the squelch threshold.
	Transmitter's RF signal is too weak	Reduce the distance between transmitter and receiver.
	Antennas are not correctly connected	Check the antenna cables or the antennas
During the soundcheck, only one diversity display (I or II) appears on the display panel	One of the antennas is not correctly connected or not optimally positioned	Check the antenna cables or the antennas and reposition the antennas.

If a problem occurs that is not listed in the above table or if the problem cannot be solved with the proposed solutions, please contact your local Sennheiser partner for assistance. To find a Sennheiser partner in your country, search at www.sennheiser.com under "Service & Support".



For accessories, visit the ew G3 product page at www.sennheiser.com.

Specifications

RF characteristics

Modulation	wideband FM
Receiving frequency ranges	516–558, 566–608, 626–668, 734–776, 780–822, 823–865 MHz (A to E, G, see page 4)
Receiving frequencies	1,680 frequencies, tuneable in steps of 25 kHz 20 frequency banks, each with up to 12 factory-preset channels, intermodulation-free 1 frequency bank with up to 12 user programmable channels
Switching bandwidth	42 MHz
Nominal/peak deviation	±24 kHz/±48 kHz
Receiver principle	true diversity
Sensitivity (with HDX, peak deviation)	< 2.5 µV for 52 dBA _{rms S/N}
Adjacent channel rejection	typ. ≥ 65 dB
Intermodulation attenuation	typ. ≥ 65 dB
Blocking	≥ 70 dB
Squelch	Off, Low: 5 dBµV, Middle: 15 dBµV, High: 25 dBµV
Pilot tone squelch	can be switched off
Antenna inputs	2 BNC sockets

AF characteristics

Compander system	Sennheiser HDX
EQ presets (switchable, affect the line and monitor outputs):	
Preset 1: "Flat"	
Preset 2: "Low Cut"	-3 dB at 180 Hz
Preset 3: "Low Cut/High Boost"	-3 dB at 180 Hz +6 dB at 10 kHz
Preset 3: "High Boost"	+6 dB at 10 kHz
S/N ratio (1 mV, peak deviation)	≥ 110 dBA
THD	≤ 0.9 %
AF output voltage (at peak deviation, 1 kHz AF)	¼" (6.3 mm) jack socket (unbalanced): +12 dBu XLR socket (balanced): +18 dBu
Adjustment range of audio output level "AF OUT"	48 dB (in steps of 3 dB) +6 dB gain reserve

Overall device

Temperature range	-10°C to +55°C
Power supply	12 V ===
Current consumption	300 mA
Dimensions	approx. 190 mm x 212 mm x 43 mm
Weight	approx. 980 g

Specifications

In compliance with (EM 100)

Europe

CE EMC EN 301489-1/-9
Radio EN 300422-1/-2
Safety EN 60065

USA

FC 47 CFR 15 subpart B

Approved by (EM 100)

Canada

Industry Canada RSS 210, IC: 2099A-G3EM100

Mains unit*

	NT 2-1	NT 2-3
Input voltage	110 V~ or 230 V~, 50/60 Hz	100 to 240 V~, 50/60 Hz
Power/current consumption	9 VA	max. 120 mA
Output voltage	13 V ===	12 V ===
Secondary output current	300 mA	400 mA
Temperature range	-10°C to +40°C	-10°C to +40°C

* depending on country variant

In compliance with

Europe

CE EMC NT 2-3: EN 55022, EN 55024,
EN 55014-1/-2
NT 2-1: EN 55013, EN 55020,
EN 55014-1/-2
Safety EN 60065

USA



FC 47 CFR 15 subpart B

Canada

ICES 003

The mains unit is certified in accordance with the legal safety requirements of Europe, the United States, Canada, Russia and Japan.

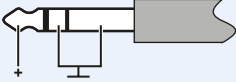
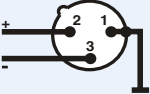
Connector assignment

Audio		Other connectors
<p>¼" (6.3 mm) stereo jack plug, balanced</p> 	<p>XLR-3F connector, balanced</p> 	<p>DC connector for power supply</p> 
<p>¼" (6.3 mm) mono jack plug, unbalanced</p> 		

Manufacturer Declarations

Warranty

Sennheiser electronic GmbH & Co. KG gives a warranty of 24 months on this product.

For the current warranty conditions, please visit our web site at www.sennheiser.com or contact your Sennheiser partner.

In compliance with the following requirements

- RoHS Directive (2002/95/EU)
- WEEE Directive (2002/96/EU)



Please dispose of the receiver at the end of its operational lifetime by taking it to your local collection point or recycling center for such equipment.

CE Declaration of Conformity

- **CE 0682**
- R&TTE Directive (1999/5/EU), EMC Directive (2004/108/EU), Low Voltage Directive (2006/95/EU)
The declarations are available at www.sennheiser.com.
Before putting the device into operation, please observe the respective country-specific regulations.

Statements regarding FCC and Industry Canada

This device complies with Part 15 of the FCC Rules and with RSS-210 of Industry Canada. Operation is subject to the following two conditions: (1) this device may not cause harmful interference, and (2) this device must accept any interference received, including interference that may cause undesired operation.

This equipment has been tested and found to comply with the limits for a Class B digital device, pursuant to Part 15 of the FCC Rules. These limits are designed to provide reasonable protection against harmful interference in a residential installation. This equipment generates, uses and can radiate radio frequency energy and, if not installed and used in accordance with the instructions, may cause harmful interference to radio communications. However, there is no guarantee that interference will not occur in a particular installation. If this equipment does cause harmful interference to radio or television reception, which can be determined by turning the equipment off and on, the user is encouraged to try to correct the interference by one or more of the following measures:

- Reorient or relocate the receiving antenna.
- Increase the separation between the equipment and receiver.
- Connect the equipment into an outlet on a circuit different from that to which the receiver is connected.
- Consult the dealer or an experienced radio/TV technician for help.
- This class B digital device complies with the Canadian ICES-003.

Changes or modifications made to this equipment not expressly approved by Sennheiser electronic Corp. may void the FCC authorization to operate this equipment.

Before putting the device into operation, please observe the respective country-specific regulations!

Sennheiser electronic GmbH & Co. KG
Am Labor 1, 30900 Wedemark, Germany
www.sennheiser.com

Printed in Germany
Publ. 01/09
529663/A01